

**MATHEMATICAL MODELING
IN PHYSICS AND ENGINEERING**



Wydawnictwo Wydziału Zarządzania
Politechniki Częstochowskiej

Częstochowa 2018

Scientific editors:

Andrzej Grzybowski
Jolanta Pozorska

Technical editors:

Katarzyna Freus
Katarzyna Szota

Cover design:

Tomasz Błaszczuk
Jock Cooper, www.fractal-recurrious.com

Scientific committee:

Andrzej Grzybowski CUT - **Chair**
Tomasz Błaszczuk CUT
Jan Čapek UP
Mariusz Ciesielski CUT
Zbigniew Domański CUT
Andrzej Drzewiński UZG
Małgorzata Klimek CUT
Bohdan Kopytko CUT
Mariusz Kubanek CUT
Stanisław Kukła CUT
Adam Kulawik CUT
Jacek Leszczyński AGH UST
Zhbing Li SYSU
Ewa Majchrzak SUT

Bohdan Mochnacki UOSM
Valerie Novitzká, TUK
Antoni Pierzchalski UL
Jolanta Pozorska CUT
Zbigniew Pozorski PUT
Piotr Puchała CUT
Grażyna Rygał JDU
Norbert Szczygiol CUT
Urszula Siedlecka CUT
Krzysztof Sokół CUT
William Steingartner TUK
Oleg Tikhonenko CWU
Jerzy Winczek CUT
Izabela Zamorska CUT

Organizing committee:

Jolanta Pozorska -**Conference General
Manager**
Urszula Siedlecka- **Secretary**
Izabela Zamorska - **Secretary**
Jolanta Borowska

Mariusz Ciesielski
Zbigniew Domański
Katarzyna Freus
Andrzej Grzybowski
Katarzyna Szota

The materials submitted by the authors were reviewed and accepted by the Scientific Committee

ISBN

© Copyright by Wydawnictwo Wydziału Zarządzania
Politechniki Częstochowskiej
Częstochowa 2018

Wydawnictwo Wydziału Zarządzania Politechniki Częstochowskiej
42-200 Częstochowa, al. Armii Krajowej 36 B
tel. 34 325 04 80, dystrybucja 34 325 08 67
e-mail: wyd.wz@zim.pcz.pl

The conference Mathematical Modeling in Physics and Engineering – MMPE'18 is organized by Czestochowa Branch of Polish Mathematical Society jointly with the Institute of Mathematics of Czestochowa University of Technology.

Mathematical modeling is at the core of contemporary research within a wide range of fields of science and its applications. The MMPE'18 focuses on various aspects of mathematical modeling and usage of computer methods in modern problems of physics and engineering. The goal of this conference is to bring together mathematicians and researchers from physics and diverse disciplines of technical sciences. Apart from providing a forum for the presentation of new results, it creates a platform for exchange of ideas as well as for less formal discussions during the evening social events which are planned to make the conference experience more enjoyable.

This year's conference is organized for the 10th time. Every year the conference participants represent a prominent group of recognized scientists as well as young researchers and PhD students from domestic and foreign universities. This time we have invited speakers from Silesian University of Technology and University of Occupational Safety Management in Katowice as well as from other higher education institutions: Technical University of Košice, Vasyl Stefanyk Precarpathian National University, Jan Długosz University, Poznan University of Technology, University of Lodz and Technical University of Czestochowa.

Organizers

CONTENTS

1. NUMERICAL ALGORITHMS FOR FRACTIONAL OPERATORS Krzysztof Bekus.....	9
2. POLYNOMIAL MAPPINGS WHICH HAVE TWO ZEROS AT INFINITY Grzegorz Biernat.....	11
3. FRACTIONAL STURM-LIOUVILLE PROBLEM WITH DIFFERENT TYPES OF BOUNDARY CONDITIONS – NUMERICAL APPROACH Tomasz Błaszczuk, Mariusz Ciesielski, Małgorzata Klimek	13
4. CLASSIFICATION OF THE BRAVAIS LATTICE AND CRYSTALLINE STRUCTURES Lena Caban, Joanna Kurek	15
5. APPLICATION OF THE KRONECKER TENSOR PRODUCT FOR MODELLING THE DEPTH OF NITROGEN DIFFUSION PROCESS Anita Ciekot.....	17
6. FIBER BUNDLE MODEL WITH FRÉCHET DISTRIBUTED BREAKING THRESHOLDS Tomasz Derda.....	19
7. MIXED MATRIX PROBLEMS AND THEIR APPLICATIONS Nadiya Gubareni.....	21
8. ON ONE CLASS OF NONLOCAL PARABOLIC CONJUGATION PROBLEMS IN THE THEORY OF DIFFUSION PROCESSES WITH MEMBRANES Bohdan Kopytko, Roman Shevchuk	22
9. A NEW APPROACH TO SPEECH RECOGNITION USING CONVOLUTIONAL NEURAL NETWORKS Mariusz Kubanek.....	24
10. FRACTIONAL HEAT CONDUCTION IN A COMPOSITE CYLINDER Stanisław Kukła, Urszula Siedlecka	31

11. ABOUT SOME UNIFORMLY BOUNDED SUPERPOSITION OPERATORS Maria Lupa, Małgorzata Wróbel	33
12. A FEW WORDS ABOUT SUPPLY AND DEMAND Ewa Ładyga, Marek Ładyga.....	35
13. METHODS OF MULTIDIMENSIONAL COMPARISON ANALYSIS IN ENTERPRISE MANAGEMENT Marek Ładyga, Ewa Ładyga.....	38
14. APPLICATION OF NUMERICAL METHODS FOR SOLVING THE NON-FOURIER EQUATIONS. REVIEW OF OWN AND COLLABORATORS WORKS Ewa Majchrzak, Bohdan Mochnacki.....	42
15. THE ADVANTAGES OF LINEAR LOGIC IN COMPUTER SCIENCE Valerie Novitzká, William Steingartner, Mohamed Ali M. Eldojali.....	44
16. FRACTIONAL HEAT CONDUCTION AND DIFFUSION EQUATIONS AND ASSOCIATED THEORIES OF THERMAL AND DIFFUSIVE STRESSES Yuriy Povstenko	51
17. THE INFLUENCE OF THE BOUNDARY CONDITIONS ON THE SHEAR STRESSES IN SANDWICH PANELS SUBJECTED TO TORSION Zbigniew Pozorski, Szymon Wojciechowski	52
18. CONVERGENCE OF THE SEQUENCES OF HOMOGENEOUS YOUNG MEASURES Piotr Puchała.....	54
19. MATHEMATICAL THINKING AS AN INDISPENSABLE SKILL TO SOLVE BOTH EVERYDAY PROBLEMS AND PURELY MATHEMATICAL ISSUES Grażyna Rygał	56
20. THE CONTROL OF LOCAL AND GLOBAL INSTABILITY REGIONS OF THE SLENDER STRUCTURES Krzysztof Sokół	57

21. REMARKS ABOUT GEOMETRIC SCALE IN ANALYTIC HIERARCHY PROCESS Tomasz Starczewski	59
22. NEW LEARNING TOOLS FOR TEACHING THE SEMANTICS OF PROGRAMMING LANGUAGES William Steingartner, Valerie Novitzká	63
23. THE INFLUENCE OF MOUNTING RIGIDITY ON STABILITY AND STRENGTH OF CYLINDER BARRELS OF A TELESCOPIC HYDRAULIC CYLINDER Sebastian Uzny, Łukasz Kutrowski	69
24. NONLINEAR COMPONENT OF FREE VIBRATION FREQUENCY OF PARTIALLY TENSIONED SYSTEM WITH CONSIDERATION OF ROTATIONAL STIFFNESS OF SUPPORT Sebastian Uzny, Michał Osadnik.....	73
25. THE DETERMINATION OF STRESS-STRAIN RELATIONS FOR STEELS CONSIDERING THE INFLUENCE OF TEMPERATURE Jerzy Winczek.....	77
26. COMPARISON OF THE ANALYTICAL AND NUMERICAL SOLUTIONS OF THE LAPLACE EQUATION Ewa Węgrzyn-Skrzypczak, Tomasz Skrzypczak	83
27. INVERTIBLE POLYNOMIAL MAPPINGS WHICH HAVE ONE ZERO AT INFINITY STABILITY Magdalena Woźniakowska	85
28. DIFFERENTIAL TRANSFORMATION METHOD FOR A CANTILEVER BEAM WITH DAMAGE Izabela Zamorska.....	87
THE DIDACTIC PANEL	89
29. PROFESSIONAL PRACTICES IN THE STUDY PROGRAM ACCORDING TO LAW 2.0. REGIONAL POSSIBILITIES OF PROFESSIONAL PRACTICES Jolanta Borowska.....	91

30. INTERDISCIPLINARY STUDIES ACCORDING TO LAW 2.0 Joanna Klekot	92
31. THE REQUIREMENTS FOR GRANTING THE RIGHT TO CONDUCT STUDIES WITH A PRACTICAL PROFILE IN THE CONTEXT OF THE HIGHER EDUCATION AND SCIENCE LAW (ACT 2.0) Sylwia Lara-Dziembek	93
32. THE REQUIREMENTS FOR GRANTING THE RIGHT TO CONDUCT STUDIES WITH A GENERAL ACADEMIC PROFILE IN THE CONTEXT OF THE HIGHER EDUCATION AND SCIENCE LAW (ACT 2.0) Edyta Pawlak	94
33. PRINCIPLES OF CLASSIFICATION OF SCIENTIFIC DISCIPLINES ACCORDING TO LAW 2.0 (LAW ON HIGHER EDUCATION AND SCIENCE), STATE ON JUNE 2018 Jowita Rychlewska	95

NUMERICAL ALGORITHMS FOR FRACTIONAL OPERATORS

Krzysztof Bekus

*Institute of Mathematics, Czestochowa University of Technology,
Czestochowa, Poland
krzysztof.bekus@im.pcz.pl*

Keywords: fractional calculus, Caputo derivative, numerical methods

Fractional calculus is used in mechanics, biology, economy, chemistry and other areas of science. In recent years scientists research more and more about this topic and many interesting articles and books were published. Fractional operators has been described in a lot of works (see example [3-7]). They have been studied from both numerical and analytical point of view. In contrast to classical derivative, where its value is determined at a given point, fractional derivatives are non-local operators. In this paper we study Caputo derivative of order $\alpha > 0$, defined as follows [1]:

$$({}^c D_{a+}^\alpha y)(x) = \frac{1}{\Gamma(n-\alpha)} \int_a^x \frac{y^{(n)}(t) dt}{(x-t)^{\alpha-n+1}} \quad (1)$$

which is left Caputo fractional operator, $n=[\alpha]+1$, and

$$({}^c D_{b-}^\alpha y)(x) = \frac{(-1)^n}{\Gamma(n-\alpha)} \int_x^b \frac{y^{(n)}(t) dt}{(t-x)^{\alpha-n+1}} \quad (2)$$

which is known as right Caputo fractional operator.

We focus our attention on Caputo derivative with fixed memory length L . These types of operators were used in [2] where the problem of one-dimensional tension of the fractional continua under linear elasticity with Dirichlet's boundary conditions was analysed.

$$\begin{cases} L^{\alpha-1} \frac{\Gamma(2-\alpha)}{2} \frac{\partial}{\partial X} ({}^c D_{a1+}^\alpha U - {}^c D_{a2-}^\alpha U) + \frac{b}{E} = 0 \\ U(X=0) = 0 \\ U(X=l) = 0.01l \end{cases} \quad (3)$$

The Caputo derivative was approximated by modified trapezoidal rule.

In this paper we apply different approach to this problem using series representation of fractional derivative with fixed memory length L . We compare both approaches by calculating numerical values of fractional derivative for particular functions.

References

- [1] Kilbas A. A., Srivastava H. M., Trujillo J. J., Theory and Applications of Fractional Differential Equations, Elsevier Science, Amsterdam 2006
- [2] Błaszczyk T., Sumelka W. Fractional Continua for linear elasticity, Archives of Mechanics 2014, 66(3), 147-172
- [3] Podlubny I., Fractional Differential Equations, Academic Press, San Diego 1999.
- [4] Błaszczyk T., Ciesielski M., Fractional oscillator equation: analytical solution and algorithm for its approximate computation, Journal of Vibration and Control 2016, 22(8) 2045-2052
- [5] Malinowska B. A., Odziejewicz T., Torres D. F. M., Advanced Methods in the Fractional Calculus of Variations, Springer International Publishing, London 2015
- [6] Błaszczyk T., Siedlecki J., Ciesielski M., A numerical solutions of a fractional oscillator equation with various types of boundary conditions, Selected Topics in Contemporary Mathematical Modeling, Publishing Office of Częstochowa University of Technology, Częstochowa 2017
- [7] Malinowska B.A., Torres D.F.M., Introduction to the Fractional Calculus of Variations, Imperial College Press, London 2012

**POLYNOMIAL MAPPINGS
WHICH HAVE TWO ZEROS AT INFINITY**

Grzegorz Biernat

*Institute of Mathematics, Czestochowa University of Technology,
Czestochowa, Poland
grzegorz.biernat@im.pcz.pl*

Keywords: **Jacobian, zeros at infinity, Jacobian Conjecture**

This work contains the theorems concerning the algebraic dependence of polynomial mappings having two zeros at infinity in the case when the leading forms of the co-ordinates of the mapping are the power of the product XY of the variables X, Y .

Let $(f, h): \mathbb{C}^2 \rightarrow \mathbb{C}^2$ be the polynomial mapping having two zeros at infinity.

Theorem 1. *Let*

$$f = (XY)^p + f_{2p-1} + f_{2p-2} + f_{2p-3} + \dots + f_1 \quad (1)$$

and

$$h = (XY)^q + h_{2q-1} + h_{2q-2} + h_{2q-3} + \dots + h_1 \quad (2)$$

where $p \geq q \geq 1$.

If $\text{Jac}(f, h) = \text{const} = \text{Jac}(f_1, h_1)$ then exist the form \hat{h}_1 for which

$$f = \left(XY + \frac{1}{q} \hat{h}_1 \right)^p + A_1 \left(XY + \frac{1}{q} \hat{h}_1 \right)^{p-1} + \dots + A_{p-1} \left(XY + \frac{1}{q} \hat{h}_1 \right) \quad (3)$$

and

$$h = \left(XY + \frac{1}{q} \hat{h}_1 \right)^q + B_1 \left(XY + \frac{1}{q} \hat{h}_1 \right)^{q-1} + \dots + B_{q-1} \left(XY + \frac{1}{q} \hat{h}_1 \right) \quad (4)$$

for some constants A_1, \dots, A_{p-1} and B_1, \dots, B_{q-1} .

The proof proceeds by induction.

Theorem 2. *Let*

$$f = (X^k Y^l)^p + f_{(k+l)p-1} + f_{(k+l)p-2} + \dots + f_{(k+l)(p-1)+1} + \dots + f_1 \quad (5)$$

$$h = (X^k Y^l)^q + h_{(k+l)q-1} + h_{(k+l)q-2} + \dots + h_{(k+l)(q-1)+1} + \dots + h_1 \quad (6)$$

where $k > l$ (k and l are relativity prim) and $p \geq q \geq 1$.

If $\text{Jac}(f, h) = \text{const} = \text{Jac}(f_1, h_1)$ then exist the forms $\hat{h}_{k+l-1}, \hat{h}_{k+l-2}, \dots, \hat{h}_1$ for which

$$\begin{aligned} f = & \left(X^k Y^l + \frac{1}{q} \hat{h}_{k+l-1} + \frac{1}{q} \hat{h}_{k+l-2} + \dots + \frac{1}{q} \hat{h}_1 \right)^p \\ & + A_1 \left(X^k Y^l + \frac{1}{q} \hat{h}_{k+l-1} + \frac{1}{q} \hat{h}_{k+l-2} + \dots + \frac{1}{q} \hat{h}_1 \right)^{p-1} \\ & \dots \\ & + A_{p-1} \left(X^k Y^l + \frac{1}{q} \hat{h}_{k+l-1} + \frac{1}{q} \hat{h}_{k+l-2} + \dots + \frac{1}{q} \hat{h}_1 \right) \end{aligned} \quad (7)$$

and

$$\begin{aligned} h = & \left(X^k Y^l + \frac{1}{q} \hat{h}_{k+l-1} + \frac{1}{q} \hat{h}_{k+l-2} + \dots + \frac{1}{q} \hat{h}_1 \right)^q \\ & + B_1 \left(X^k Y^l + \frac{1}{q} \hat{h}_{k+l-1} + \frac{1}{q} \hat{h}_{k+l-2} + \dots + \frac{1}{q} \hat{h}_1 \right)^{q-1} \\ & \dots \\ & + B_{q-1} \left(X^k Y^l + \frac{1}{q} \hat{h}_{k+l-1} + \frac{1}{q} \hat{h}_{k+l-2} + \dots + \frac{1}{q} \hat{h}_1 \right) \end{aligned} \quad (8)$$

for some constants A_1, \dots, A_{p-1} and B_1, \dots, B_{q-1}

The proof of the theorem also goes through induction.

References

- [1] Abhyankar S.S., Expansion techniques in algebraic geometry, Tata Inst. Fundamental Research, Bombay, 1977.
- [2] Charzyński Z., Chądzyński J., Skibinski P., A contribution to Keller's Jacobian Conjecture, Lecture Notes In Math. 1165, Springer-Verlag, Berlin Heidelberg N. York, 36-51, 1985.
- [3] Bass H., Connell E.H., Wright D., The Jacobian conjecture: reduction of degree and formal expansion of the inverse, American Mathematical Society. Bulletin. New Series 7 (2): 287-330, 1982.

**FRACTIONAL STURM-LIOUVILLE PROBLEM WITH
DIFFERENT TYPES OF BOUNDARY CONDITIONS –
NUMERICAL APPROACH**

Tomasz Błaszczuk¹, Mariusz Ciesielski², Małgorzata Klimek³

¹*Institute of Mathematics, Czestochowa University of Technology,
Czestochowa, Poland*

²*Institute of Computer and Information Sciences, Czestochowa University of Technology,
Czestochowa, Poland*

³*Institute of Mathematics, Czestochowa University of Technology,
Czestochowa, Poland*

¹*tomasz.blaszczuk@im.pcz.pl, ²mariusz.ciesielski@icis.pcz.pl, ³mklimek@im.pcz.pl*

Keywords: **fractional calculus, Sturm-Liouville Problem, numerical solution**

In the paper, we study the regular fractional Sturm-Liouville problem (FSLP) in a bounded domain

$${}^c D_{b^-}^\alpha \left(p(x) {}^c D_{a^+}^\alpha y(x) \right) + q(x) y(x) = \lambda w(x) y(x) \quad (1)$$

subject to different types of boundary conditions

- mixed boundary conditions

$$y(a) = 0, \quad p(x) {}^c D_{a^+}^\alpha y(x) \Big|_{x=b} = 0 \quad (2)$$

- von Neumann boundary conditions

$$I_{b^-}^{1-\alpha} p(x) {}^c D_{a^+}^\alpha y(x) \Big|_{x=a} = 0, \quad I_{b^-}^{1-\alpha} p(x) {}^c D_{a^+}^\alpha y(x) \Big|_{x=b} = 0 \quad (3)$$

The problem of finding an exact solution of the FSLP, where the Laplacian consist of both the left and right fractional derivatives [1], is still a big challenge for scientists. Hence, a numerical approach to solving the studied FSLP is only way (at present) to calculate the respective eigenvalues (approximate eigenvalues).

In this work we discussed a numerical schemas to calculate the approximate eigenvalues and eigenfunctions for the analysed FSLP, by utilizing the approach presented in papers [2, 3, 4]. First, we transform the Euler-Lagrange equation into an integral equation. Afterwards we discretize the obtained equation by using the numerical quadrature rule based on linear interpolation. This method leads to the numerical scheme for which the experimental rate of convergence, in all the considered cases (mixed and Neumann boundary conditions), tends to 2α . It should

be highlighted that the orthogonality of the approximate eigenfunctions is kept at each step of procedures.

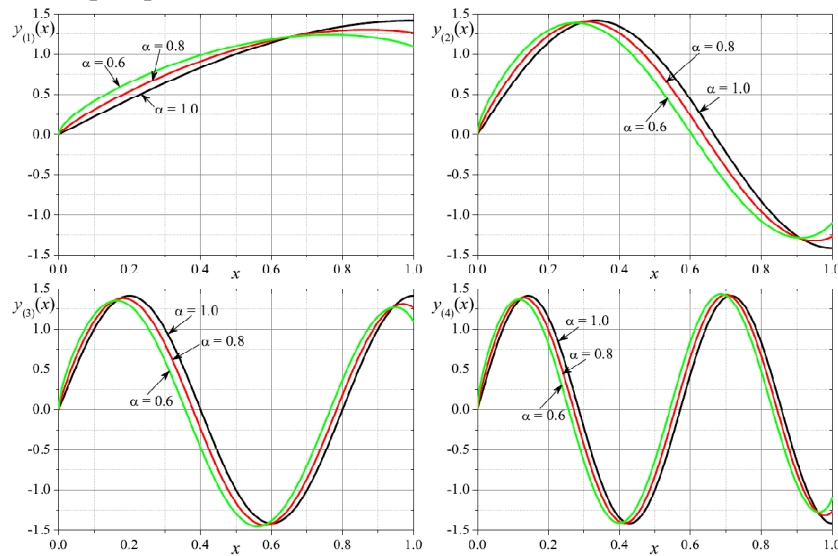

Fig. 1. Eigenfunctions for the first 4 eigenvalues for order $\alpha \in \{0.6, 0.8, 1\}$

As the numerical example we consider the generalization of the classical harmonic oscillator problem with $p = 0$, $w = 1$ and $q = 0$. Eigenfunctions for the first 4 eigenvalues are presented in Figure 1.

References

- [1] Ciesielski M., Klimek M., Blaszczyk T., The Fractional Sturm-Liouville Problem - Numerical Approximation and Application in Fractional Diffusion, Journal of Computational and Applied Mathematics 2017, 317, 573-588.
- [2] Blaszczyk T., Ciesielski M., Numerical solution of fractional Sturm-Liouville equation in integral form. Fract. Calc. Appl. Anal. 2014, 17(2), 307-320.
- [3] Blaszczyk T., Ciesielski M., Fractional oscillator equation - transformation into integral equation and numerical solution. Appl. Math. Comput. 2015, 257, 428-435.
- [4] Klimek M., Ciesielski M., Blaszczyk T., Exact and numerical solutions of the fractional Sturm-Liouville problem. Fract. Calc. Appl. Anal. 2018, 21(1), 45-71.

CLASSIFICATION OF THE BRAVAIS LATTICE AND CRYSTALLINE STRUCTURES

Lena Caban, Joanna Kurek

*Institute of Mathematics, Czestochowa University of Technology,
Czestochowa, Poland
lenacaban95@gmail.com, asiakurek19@gmail.com*

Keywords: **crystallography, Bravais lattice, crystallographic point groups**

In this paper we present the basic notions about crystal structures. At the beginning we define the Bravais lattice, named after Auguste Bravais, a French physicist, crystallographer and mathematician. In geometry and crystallography, the Bravais lattice is an infinite array of discrete points in three dimensional space, the position vectors of which have the following form

$$\vec{R} = n_1\vec{a}_1 + n_2\vec{a}_2 + n_3\vec{a}_3 \quad (1)$$

where $\vec{a}_1, \vec{a}_2, \vec{a}_3$ are known as primitive (basis) vectors which are linearly independent and spans the lattice and n_1, n_2, n_3 are any integers. For any choice of position vector \vec{R} , the lattice looks exactly the same.

The Bravais lattice determines the nature of periodic ordering of the repeating structural elements of the crystal in space. These elements can be single atoms, groups of atoms, ions, or polymer strings of solid matter.

In two-dimensional space, there are 5 Bravais lattices, grouped into four crystal families. In three-dimensional space, there are 14 Bravais lattices. These are obtained by combining one of the seven lattice systems with one of the centering types. The centering types indicate the locations of the lattice points in the unit cell.

Then we consider crystallographic point groups and space groups. The crystallographic point group or the crystal class is a set of symmetry operations with one fixed lattice point. These symmetry operations include reflection, inversion, rotation, improper rotation (without translation). The crystal structure determines the existence of 32 crystallographic point groups. We present them in two notations: Hermann–Mauguin notation and Schoenflies notation. The first notation is named after Carl Hermann, the German crystallographer and Charles-Victor Mauguin, the French mineralogist. This notation is also called international notation, because it was adopted as standard by the International Tables For Crystallography. The second notation is named after Arthur Moritz Schoenflies, the German mathematician, known for his contributions to the application of group theory to crystallography. The Schoenflies notation is mainly used in spectroscopy.

The space group of the crystal structure additionally contains translational symmetry operations. These include pure translations, screw axes and glide planes. There are 230 possible space groups.

Finally, we will provide some important examples of crystalline structures along with chemical elements crystallizing in these structures.

References

- [1] Ashcroft N.W., Mermin N.D., Solid State Physics, Holt, Rinehart and Winston, 1976.
- [2] Ibach H. Luth H., Solid-State Physics. An Introduction to Principles of Materials Science, Springer-Verlag Berlin Heidelberg 1995.
- [3] Kittel C., John Wiley & Sons, 1976.

APPLICATION OF THE KRONECKER TENSOR PRODUCT FOR MODELLING THE DEPTH OF NITROGEN DIFFUSION PROCESS

Anita Ciekot

*Institute of Mathematics, Czestochowa University of Technology,
Czestochowa, Poland
anita.ciekot@im.pcz.pl*

Keywords: polynomial interpolation, Kronecker tensor product, depth of nitrogen diffusion

In this paper a new formula of tensor interpolation by polynomial of two variables is applied to modelling the depth of nitrogen diffusion process of austenitic steel type 316L. The coefficients of interpolating polynomial were formulated by using the Kronecker tensor product. Headers should include the name of the conference.

The process of plasma nitriding was describe by the interpolating polynomial of two variables: temperature and time. The measurements were performed in hydrogen-nitrogen plasma for the following parameters: temperature $T = 325 - 400$ C and time of the process $t = 2 - 4$ h. The specimens were located directly on the cathode. During the experimental plasma nitrogen process the following values of diffusion depth were obtained:

$$[(w_c)_{jl}] = [0.56; 0.98; 1.01; 0.88; 1.38; 1.80; 1.44; 1.96; 2.15; 1.61; 2.26; 2.51]^{transp}$$

In this case the interpolating polynomial is expressed by the following formula:

$$W_c(T, t) = \sum_{\substack{1 \leq i \leq 4 \\ 1 \leq k \leq 3}} (c_c)_{ik} T^{i-1} t^{k-1}$$

with coefficients

$$(c_c)_{ik} = (-1)^{i+k} \sum_{\substack{1 \leq j \leq 4 \\ 1 \leq l \leq 3}} (-1)^{j+l} (w_c)_{jl} \frac{\tau_{4-i}(T_1, \hat{T}_j, \dots, T_4)}{\pi_{1j}} \cdot \frac{\tau_{3-k}(t_1, \hat{t}_j, \dots, t_3)}{\pi_{2l}}$$

where

$$\begin{aligned}
 \pi_{11} &= (T_4 - T_1)(T_3 - T_1)(T_2 - T_1) & \pi_{21} &= (T_3 - T_1)(T_2 - T_1) \\
 \pi_{12} &= (T_4 - T_2)(T_3 - T_2)(T_2 - T_1) & \pi_{22} &= (T_3 - T_2)(T_2 - T_1) \\
 \pi_{13} &= (T_4 - T_3)(T_3 - T_2)(T_3 - T_1) & \pi_{23} &= (T_3 - T_2)(T_3 - T_1) \\
 \pi_{14} &= (T_4 - T_3)(T_4 - T_2)(T_4 - T_1)
 \end{aligned}$$

$\tau_{4-i}(T_1, \dots, \hat{T}_j, \dots, T_4)$ and $\tau_{3-k}(t_1, \dots, \hat{t}_j, \dots, t_3)$ are the fundamental symmetric polynomials of rank 4 and 3 of the variables $T_1, \dots, \hat{T}_j, \dots, T_4$ and $t_1, \dots, \hat{t}_j, \dots, t_3$ respectively. The symbol \hat{T}_j means omitting the variable T_j .

Here, $[T_i^j]$ describes temperature of the nitriding process, and $[t_k^l]$ times of exposition of a specimen in given temperature.

The computations have been performed by using the Maple software.

References

- [1] Graham A., Kronecker Products and Matrix Calculus with Applications, Ellis Horwood LTD., 1981.
- [2] Kincaid D., Chnej W., Numerical Analysis, Mathematics of Scientific Computing, The University of Texas at Austin, 2002.
- [3] Biernat G., Ciekot A., The Polynomial Interpolation for technical experiments, Scientific Research of the Institute of Mathematics and Computer Science, 2007, 1.
- [4] Ogórek M., Biernat G., Frączek T., Knapieński M., Polynomial Interpolation of the obtained depth of nitrogen diffusion on the surface of the plasma nitrided X5CrNi18-10 austenitic steel, Journal of Applied Mathematics and Computational Mechanics 2015, 14(3),79-85.

FIBER BUNDLE MODEL WITH FRÉCHET DISTRIBUTED BREAKING THRESHOLDS

Tomasz Derda

*Institute of Mathematics, Czestochowa University of Technology
Czestochowa, Poland
tomasz.derda@im.pcz.pl*

Keywords: **fracture, fiber bundle model, load transfer, extreme value distribution**

Fiber Bundle Model (FBM), with statistically distributed strength-thresholds of the individual fibers, is one of the most common theoretical approaches used to investigate the fracture and breakdown of disordered materials [1-2].

We consider a two-dimensional bundle of fibers consisting of a $N = L \times L$ fibers organized on a square lattice and clamped at both ends. The bundle is subjected to a quasi-statically increased load F parallel to the fibers' direction. The fibers break if the load applied on them exceeds their strength-threshold σ_{th}^i , $i = 1, \dots, N$. The load carried by the destroyed fibers is transferred among the surviving fibers according to a given load transfer rule. We explore two classical load transfer rules, namely global load sharing (GLS) and local load sharing (LLS).

The strengths of the fibers are independent and identically distributed quenched random variables. Most of the studies deal with uniform or Weibull distribution of strength-thresholds. The Weibull distribution is a type III extreme value distribution and relates to minima. In this study, we employ the Fréchet distribution, also known as type II extreme value distribution. This distribution, bounded from below and characterised by heavy upper tail, can be seen as the inverse Weibull distribution. Cumulative distribution function of strength-thresholds is given by:

$$P(\sigma_{th}) = \exp \left\{ - \left(\frac{\sigma_{th}}{\gamma} \right)^{-m} \right\} \quad (1)$$

where m and γ are shape and scale parameter, respectively.

We performed numerical simulations of the loading process for bundles with a number of fibers ranging from $N = 8 \times 8$ to $N = 320 \times 320$. Analysis is restricted to the cases with finite mean and finite variance of strength-thresholds ($m > 2$). The scale parameter is assumed to be 1. Application of quasi-static loading allows one to obtain minimal load F_c that is needed for destruction of the bundle. Critical loads are scaled by the appropriate bundle sizes $\sigma_c = F_c / N$.

We have found that for the GLS rule the mean critical load $\langle \sigma_c \rangle$ asymptotically tends to

$$\langle \sigma_c \rangle \xrightarrow{N \rightarrow \infty} (-\ln \xi(m))^{-m^{-1}} (1 - \xi(m)) \quad (2)$$

and $\xi(m)$ represents the function

$$\xi(m) = -\left(m \cdot W_{-1}\left(-m^{-1} \exp(-m^{-1})\right)\right)^{-1} \quad (3)$$

where $W_{-1}\left(-m^{-1} \exp(-m^{-1})\right)$ is a Lambert W function.

For finite N the following formula is proposed (see Fig. 1)

$$\langle \sigma_c \rangle = (-\ln \xi(m))^{-m^{-1}} (1 - \xi(m)) \left(1 + \frac{0.9244 \exp(m^{-1})}{m^{0.5619}} N^{-0.6684(\ln m)^{-0.0406}}\right). \quad (4)$$

In this work, we have also investigated values of the mean critical loads for the LLS rule and distribution of critical loads.

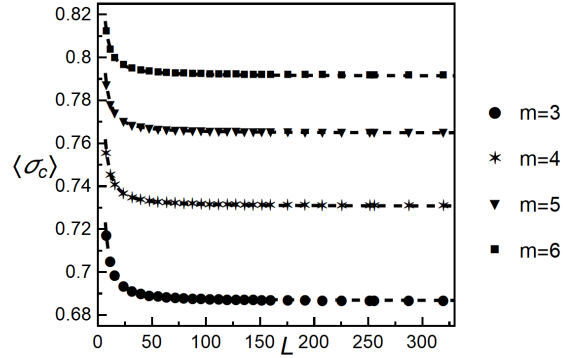

Fig.1. The mean critical load versus linear system size for different values of shape parameter. The dashed lines represent fitting by (4).

References

- [1] Hansen A., Hemmer P. C., Pradhan S., The Fiber Bundle Model: Modeling Failure in Materials, Wiley 2015.
- [2] Pradhan S., Hansen A., Chakrabarti B.K., Failure Processes in Elastic Fiber Bundles, Rev. Mod. Phys. 2010, 82, 499-555.

**MIXED MATRIX PROBLEMS
AND THEIR APPLICATIONS**

Nadiya Gubareni

*Institute of Mathematics, Czestochowa University of Technology,
Czestochowa, Poland
nadiya.gubareni@yahoo.com*

In this talk we present review and some new results on solving mixed matrix problems over rings, fields and skew fields. They often arise and have a lot of applications in various branches of mathematics such as linear algebra and theory of representations of rings and algebras.

**ON ONE CLASS OF NONLOCAL PARABOLIC CONJUGATION
PROBLEMS IN THE THEORY OF DIFFUSION PROCESSES WITH
MEMBRANES**

Bohdan Kopytko¹, Roman Shevchuk²

¹*Institute of Mathematics, Czestochowa University of Technology,
Czestochowa, Poland*

²*Vasyl Stefanyk Precarpathian National University,
Ivano-Frankivsk, Ukraine*

¹*bohdan.kopytko@im.pcz.pl, ²r.v.shevchuk@gmail.com*

Keywords: diffusion, parabolic potential, conjugation problem

Consider two intervals on a number line $\mathbb{R} : D_{1s} = \{x \in \mathbb{R} : r_1(s) < x < r_0(s)\} = (r_1(s), r_0(s))$ and $D_{2s} = \{x \in \mathbb{R} : r_0(s) < x < r_2(s)\} = (r_0(s), r_2(s))$, where $r_m(s)$, $s \in [0, T]$ ($T > 0$ is fixed), $m = 0, 1, 2$ are the given functions. Assume that $r_1(s) < r_0(s) < r_2(s)$, $s \in [0, T]$ and the functions $r_m(s)$, $m = 0, 1, 2$ belong to the Hölder class $H^{\frac{1+\alpha}{2}}([0, T])$, $0 < \alpha < 1$. Let

$$L_s^{(i)} := \frac{1}{2} b_i(s, x) \frac{d^2}{dx^2} + a_i(s, x) \frac{d}{dx}$$

be the generating differential operator of some inhomogeneous diffusion process given on D_{is} , $i = 1, 2$. Assume that the coefficients $a_i(s, x)$ and $b_i(s, x)$ of the operator $L_s^{(i)}$ are defined in the domain $(s, x) \in [0, T] \times \mathbb{R}$ and have the following properties:

- 1) there exist constants b and B such that $0 < b \leq b_i(s, x) \leq B$ for all $(s, x) \in [0, T] \times \mathbb{R}$;
- 2) function $a_i(s, x)$ is bounded on $[0, T] \times \mathbb{R}$;
- 3) for all $s, s_1 \in [0, T]$, $x, x_1 \in \mathbb{R}$ the next inequalities hold:

$$|a_i(s, x) - a_i(s_1, x_1)| \leq c(|s - s_1|^{\frac{\alpha}{2}} + |x - x_1|^\alpha),$$

$$|b_i(s, x) - b_i(s_1, x_1)| \leq c(|s - s_1|^{\frac{\alpha}{2}} + |x - x_1|^\alpha),$$

where c and α are positive constants, $0 < \alpha < 1$.

These properties ensures the existence of the fundamental solution of the parabolic operator $\frac{\partial}{\partial s} + L_s^{(i)}$.

Consider the problem of existence of the two-parameter Feller semigroup T_{st} , $0 \leq s \leq t \leq T$, associated with a Markov process on $[r_1(s), r_2(s)]$ such that its

parts in D_{1s} and D_{2s} coincide with the diffusion processes given there by $L_s^{(1)}$ and $L_s^{(2)}$ respectively and its continuations after the diffusion particle reaches the boundaries of these domains are determined by the corresponding boundary conditions and the conjugation condition of Feller-Wentzell [1, 2] additionally given at points $r_i(s)$, $i=1,2$, and $x=r_0(s)$. These conditions can be written in the form:

$$\begin{aligned} \frac{\partial T_{st} \varphi(r_i(s))}{\partial x} &= 0, \quad i=1,2, \\ q_1(s) \frac{\partial T_{st} \varphi(r_0(s)-0)}{\partial x} - q_2(s) \frac{\partial T_{st} \varphi(r_0(s)+0)}{\partial x} + \\ + \int_{D_{1s} \cup D_{2s}} (T_{st} \varphi(r_0(s)) - T_{st} \varphi(y)) \mu(s, dy) &= 0, \quad 0 \leq s < t \leq T, \quad i=1,2, \end{aligned}$$

where

- a) $q_i \in C([0, T])$, $q_i(s) \geq 0$, $q_1(s) + q_2(s) > 0$, $s \in [0, T]$, $i=1,2$;
- b) $\mu(s, \cdot)$ is the nonnegative measure on $D_{1s} \cup D_{2s}$ such that for any $\delta > 0$ the integrals

$$\int_{D_{js}^\delta} |y - r_0(s)| \mu(s, dy), \quad \int_{D_{js} \setminus D_{js}^\delta} \mu(s, dy), \quad j=1,2$$

$(D_{js}^\delta = \{y \in D_{js} : |y - r_0(s)| < \delta\})$ are continuous on $[0, T]$ as functions of variable s .

The problem formulated in the described way is also called the problem of pasting together two diffusion processes on a line or the problem of construction of the diffusion process in medium with membranes [3]. We use the analytic method to solve this problem. With such an approach the question on existence of the required semigroup in fact is being reduced to the investigation of the corresponding nonlocal initial-boundary value problem of Wentzell for a linear parabolic equation of the second order with discontinuous coefficients. The classical solvability of this problem is established by the boundary integral equations method with the use of the ordinary simple-layer potential.

References

- [1] Wentzell A.D., Semigroups of operators that correspond to a generalized differential operator of second order, Dokl. Akad. Nauk SSSR 1956, 111, 2, 269-272.
- [2] Langer H., Schenk W., Knotting of one-dimensional Feller process, Math. Nachr. 1983, 113, 151-161.
- [3] Portenko M.I., Diffusion Processes in Media with Membranes, Institute of Mathematics of the NAS of Ukraine, Kyiv, 1995.

A NEW APPROACH TO SPEECH RECOGNITION USING CONVOLUTIONAL NEURAL NETWORKS

Mariusz Kubanek

*Institute of Computer and Information Sciences, Czestochowa University of Technology,
Czestochowa, Poland
mariusz.kubanek@icis.pcz.pl*

Keywords: **speech recognition, convolutional neural networks, deep learning.**

Convolutional neural networks (CNN) have consistently shown more robustness to noise and background contamination than traditional neural networks (NN). For speech recognition, CNN apply their convolution filters across frequency, which helps to remove cross-spectral distortions and, to some extent, speaker-level variability stemming from vocal tract length differences. Convolution across time has not been considered with much enthusiasm within the speech technology community. This work presents a new approach to speech recognition, based on the specific coding of time characteristics and frequency characteristics of speech. Our idea assumes creating patterns for sounds in the form of RGB images.

Convolutional Neural Networks

Convolutional neural network (CNN) is a feed-forward artificial neural network in which the organization of neurons is similar to the animal visual cortex [1]. In order to recognize the shape of an object, the local arrangement of pixels is important. CNN starts with recognition of smaller local patterns on the image and concatenate them into more complex shapes. CNN was proved to be efficient especially in object recognition on an image. CNNs might be an effective solution to the speech recognition problem.

CNN explicitly assumes the input is an image and reflects it onto its architecture. Therefore, in my method it is necessary to encode sounds using images. CNN usually contains Convolutional layer, Pooling layer and Fully-connected layer. Convolutional layers and Pooling layers are stacked on each other, fully-connected layers at the top of the network outputs the class probabilities.

Convolutional Layer

Convolutional layer consists of neurons connected to a small region of pixels (also called the receptive field) of previous layer. The neurons in same feature map share the same weights [2]. Convolutional layer (CL) contains a set of learnable filters. One filter activates when a specific shape or blob of colour occurs within a local area [2]. Each CL has multiple filters F . Filter $f_i \in F$ is a set of learnable

weights corresponding to the neurons in previous layer. Filter is small spatially (along width and height) and extends along the full depth c of the previous layer.

Filter's size is denoted by (f_w, f_h) . Therefore one filter adds $r_w \times r_h \times c$ parameters, other weights are not considered. CL has a depth D if it recognizes D various features in the image using D various learnable filters f_1, \dots, f_d . Thus, CL contains $r_w \times r_h \times c \times d$ learnable weights. Every neuron in CL uses weights of exactly one CL's filter, many neurons use the same weights.

The neurons in CL are segmented into feature maps by the filter they are using. Neurons belonging to feature map fm_i share the same weight matrix of filter f_i . CL forms D feature maps. Usual filter sizes are 3x3, 5x5 or less frequently 7x7.

Deep Autoencoder

Autoencoder is a feed-forward neural network where expected output is equal to the input of the network – its goal is to reconstruct its own inputs. Therefore, autoencoders are belonging to the group of unsupervised learning models [2].

Usually autoencoder consists of an input layer l_0 , one or many hidden layers l_1, \dots, l_{k-1} and output layer l_k .

The *encoder* can be used for compression. Unlike Principal Component Analysis (PCA) analysis restricted to linear mapping, the *encoder* represents non-linear richer underlying structures of the data [3]. The activations of the l_c layer can be further used for classification. Fully-connected layers are appended with the size of the last corresponding to the number of labels. Usual learning algorithms are used.

Time Frequency Convolution

Traditional CNNs for speech recognition usually apply the convolution operation across frequency, providing the network with immunity to small spectral shifts, such as those introduced by speaker-specific vocal tract length differences. In cases such as reverberation, where delayed versions of reflection introduce temporal artifacts, convolution across time can be useful. Figure 1 shows block diagram of a network using two separate convolution layers, one operating across time, and the other operating across frequency.

To encode the sounds using the RGB image, the MFCC coefficients [4,5,6] for the R component were applied, the time characteristic was used for the G component, and the signal source was used for the B component. Of course, in order to create a color image, it was necessary to scale the RGB components to one size. It was assumed that individual sounds will be coded using images with a size of 120 x 120 pixels. The time characteristics for the word "seven" are shown in Figure 2. Examples of characteristics for the word "seven" are shown in Figures 3, 4 and 5.

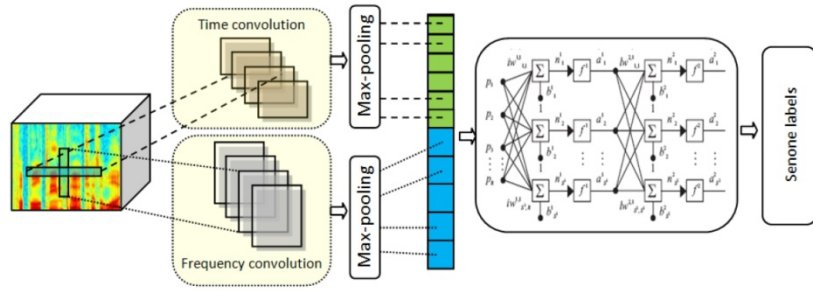

Fig. 1. Block diagram showing time-frequency convolution neural nets [7]



Fig. 2. The time characteristics for the word "seven"

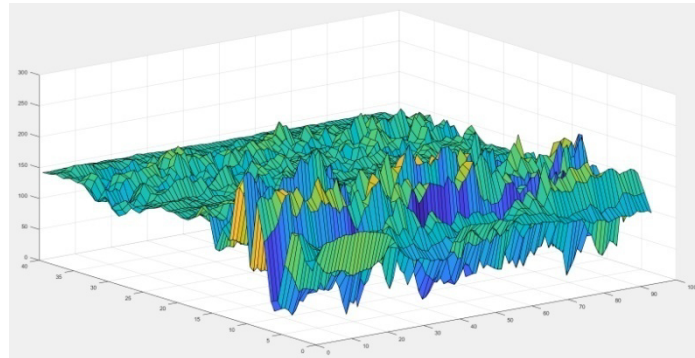

Fig. 3. Map of MFCC coefficients for the word "seven"

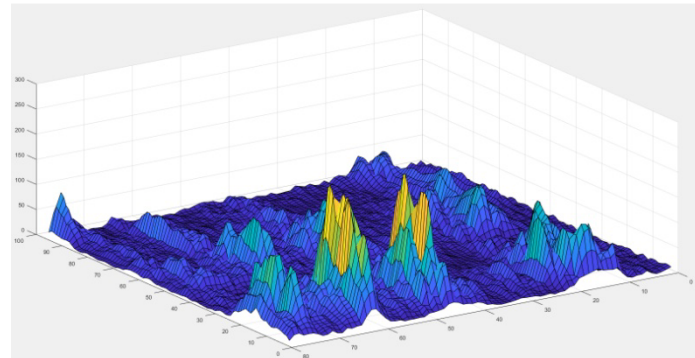

Fig. 4. The time 2D characteristics for the word "seven"

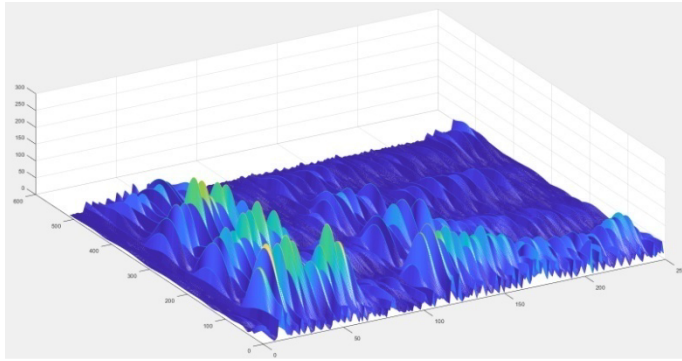

Fig. 5. Signal spectrum for the word "seven"

For such defined RGB components, it was possible to create an RGB image, which is a visual pattern for sound. It was assumed that each syllable should be coded separately. Of course, it is possible to encode combined phonemes that do not always form a syllable, but are, for example, combined with silence. In the example recording for the word "seven", the algorithm generated the division "se" - "ven". An example of the coded syllable "se" and "ven" is shown in Figure 6.

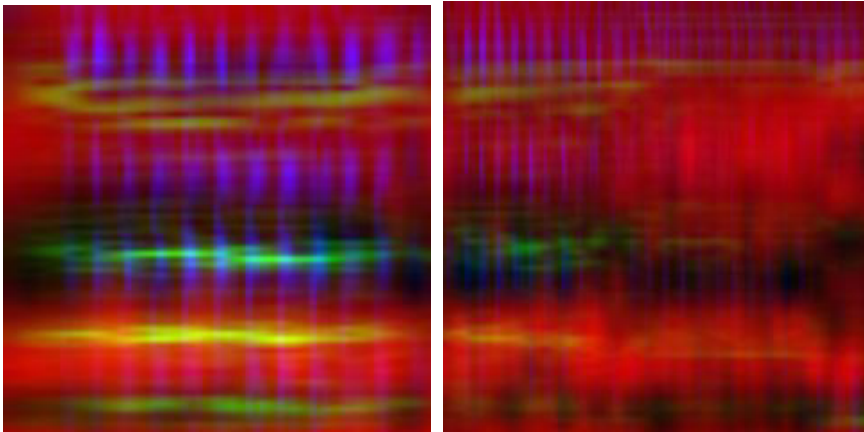

Fig. 6. An example of the coded syllable "se" (left) and "ven" (right)

Neural Network Structure

The proposed convolutional neural network consisted of 15 layers. The first convolutional layer contained 64 filters with dimensions of 9 x 9. Three convolutional layers are responsible for coding information, transferred into two fully connected layers. The network diagram is shown in Fig. 7.

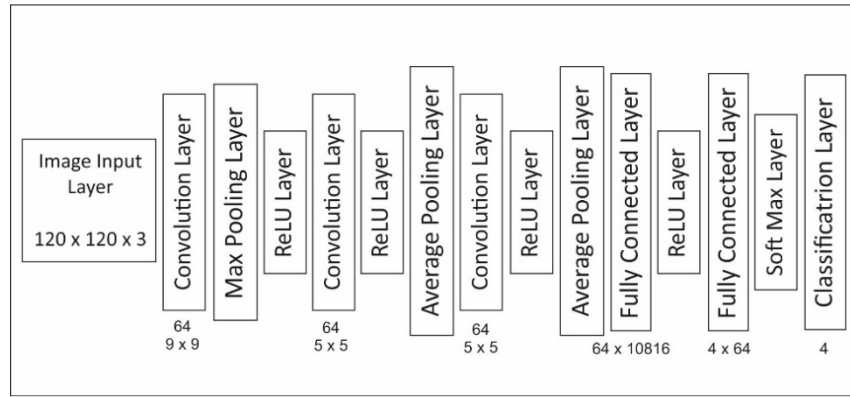

Fig. 7. Assumed network structure

Research

The studies included two important issues. The first concerned the correctness of the work of the algorithm, realizing the division of speech into syllables. A method was applied that takes into account signal energy and signal frequency for the stationary fragment under consideration. The division into individual syllables was made for the experimentally selected threshold values. For each isolated syllable (which could also include silence), the image was created as a graphic pattern. Each syllable pattern has been saved as an image in a directory name corresponding to the designated syllable. The experiment was carried out for insulated words and continuous speech. A different number of words have been adopted for continuous speech. Table 1 shows the results of an experiment concerning the division into syllables.

Table 1. Results of the division of words into syllables

Number of experiment	Type of experiment	Number of words (1) and sentences (2-4)	Correct division [%]
1	separate words	70	98
2	continuous speech (from 3 to 7 words)	40	89
3	continuous speech (from 6 to 12 words)	40	82
4	continuous speech (from 10 to 20 words)	40	69

The second type of research concerned the evaluation of the effectiveness of speech recognition for isolated words and for continuous speech. The recorded data was divided into training data and test data, in a ratio of 70 to 30. The learning time of the neural network and the number of epochs required for correct learning were also examined. The results of the main experiment are shown in Table 2.

Table 2. Speech recognition results

Number of experiment	Type of experiment	Learning time [s]	Number of epochs [%]	Word error rate [%]
1	separate words	1920	125	4.2
2	continuous speech (from 3 to 7 words)	2658	317	6.7
3	continuous speech (from 6 to 12 words)	8280	428	9.3
4	continuous speech (from 10 to 20 words)	10065	641	11.8

Conclusion and feature works

Research has shown that effective speech recognition is possible for isolated words. Appropriate speech coding by means of images allows use in convolutional neural networks. The proposed method of speech coding is an interesting alternative to the classic approach. It has been noticed that when speaking slowly, the division into syllables is quite easy. Further work will focus on increasing the efficiency of word recognition through a more accurate division into syllables. It should also be further developed algorithm MFCC, as he introduced the biggest mistakes in the visual coding of speech.

References

[1] Rawat W., Wang Z., Deep Convolutional Neural Networks for Image Classification: A Comprehensive Review, *Neural Computation* 29, 2017, 2352-2449.

[2] Bengio Y., Learning Deep Architectures for AI, *Foundations and Trends® in Machine Learning*, Volume 2 Issue 1, 2009, 1-127.

[3] Hinton G. H., Salakhutdinov.R. R., Reducing the Dimensionality of Data with Neural Networks, *Science*, Volume 313, 2006, 504-507.

[4] Sahidullah M., Goutam S., Design, analysis and experimental evaluation of block based transformation in MFCC computation for speaker recognition, *Speech Communication*, 54 (4), 2012, 543–565.

- [5] Kubanek M., Bobulski J., Adrjanowich Ł., Characteristics of the use of coupled hidden Markov models for audio-visual Polish speech recognition, *BULLETIN OF THE POLISH ACADEMY OF SCIENCES-TECHNICAL SCIENCES*, Volume 60, Issue 2, 2012, 307-316.
- [6] Kubanek M., Rydzek S., A hybrid method of user identification with use independent speech and facial asymmetry, *Lecture Notes in Artificial Intelligence*, Volume 5097, 2008, 818-827.
- [7] Mitra V., Franco H., Time-frequency convolutional networks for robust speech recognition, *IEEE Xplore*, 2015 IEEE Workshop on Automatic Speech Recognition and Understanding (ASRU), 2016, 317-323.

FRACTIONAL HEAT CONDUCTION IN A COMPOSITE CYLINDER

Stanisław Kukla, Urszula Siedlecka

*Institute of Mathematics, Czestochowa University of Technology,
Czestochowa, Poland
stanislaw.kukla@im.pcz.pl, urszula.siedlecka@im.pcz.pl*

Keywords: fractional heat conduction, Caputo derivative, composite cylinder

Mathematical modeling of the heat transfer in a composite sphere under mathematical and physical boundary conditions using the fractional differential calculus was the subject of the paper [1]. The purpose of this consideration is to investigate the effect of time-fractional order of Caputo derivatives occurring in the heat conduction equation on the temperature distribution in a composite consisting of inner solid cylinder and a cylindrical layer. The time-fractional heat transfer is governed by the following heat conduction equation [2]

$$\frac{1}{r} \frac{\partial}{\partial r} \left(r \frac{\partial T_i}{\partial r} \right) = \frac{1}{a_i} \frac{\partial^{\alpha_i} T_i}{\partial t^{\alpha_i}}, \quad i=1,2 \quad (1)$$

where a_i is the thermal diffusivity and α_i denotes the fractional order of the left-sided Caputo derivative with respect to time t .

We assume the finite temperature at the symmetry axis of the solid cylinder, the continuity conditions at the interface, the Robin boundary condition on the outer surface and the initial condition in the following form

$$|T(0,t)| < \infty \quad (2)$$

$$T_1(r_1,t) = T_2(r_1,t) \quad (3)$$

$$\lambda_1 \frac{\partial T_1}{\partial r}(r_1,t) = \lambda_2 \frac{\partial T_2}{\partial r}(r_1,t) \quad (4)$$

$$\lambda_2 \frac{\partial T_2}{\partial r}(b,t) = a_\infty (T_\infty(t) - T_2(b,t)) \quad (5)$$

$$T(r,0) = F_i(r) \quad (6)$$

where λ_i is the thermal conductivity, T_∞ is the ambient temperature and a_∞ is the outer heat transfer coefficient.

To obtain the time-fractional equation with a constant coefficients, we introduce new functions $U_i(r, t)$ given in the form

$$U_i(r, t) = T_i(r, t) - T_\infty(t), \quad i = 1, 2 \quad (7)$$

An analytical solution of the time-fractional heat conduction problem for the functions $U_i(r, t)$ under homogeneous conditions was determined by using the method of variables separation. We find the solution to the problem for the functions $U_i(r, t)$ in the form of a series

$$U_i(r, t) = \sum_{k=1}^{\infty} \Lambda_k(t) \Phi_{i,k}(r), \quad i = 1, 2 \quad (7)$$

The functions $\Phi_{i,k}(r)$ for $k = 1, 2, \dots$ are obtained as a solution of a corresponding eigenvalue problem and the function $\Lambda_k(t)$ is a solution of the appropriate fractional initial problem.

The effect of the order of the time-fractional derivative on the temperature distribution in the cylinder was investigated numerically.

References

- [1] Kukla S., Siedlecka U., Fractional heat conduction in a sphere under mathematical and physical Robin conditions, *Journal of Theoretical and Applied Mechanics* 56 (2), 2018, 339-349.
- [2] Povstenko Y., Time-fractional radial heat conduction in a cylinder and associated thermal stresses, *Archive of Applied Mechanics*, 82, 2012, 345-362.

ABOUT SOME UNIFORMLY BOUNDED SUPERPOSITION OPERATORS

Maria Lupa, Małgorzata Wróbel

*Institute of Mathematics, Czestochowa University of Technology,
Czestochowa, Poland*

maria.lupa@im.pcz.pl, malgorzata.wrobel@im.pcz.pl

Keywords: **Nemytskij operator, uniformly bounded mapping**

Let $I = [a, b]$ be an interval of the real line \mathbb{R} ($a, b \in \mathbb{R}$, $a < b$) and let \mathbb{R}^I denote the set of all functions $\varphi: I \rightarrow \mathbb{R}$. For a given function $h: I \times \mathbb{R} \rightarrow \mathbb{R}$, the mapping $H: \mathbb{R}^I \rightarrow \mathbb{R}^I$ defined by

$$H(\varphi)(x) = h(x, \varphi(x)), \quad \varphi \in \mathbb{R}^I, \quad x \in I,$$

is called a composition (Nemytskij or superposition) operator of a generator h .

In 1982 J. Matkowski proved that if H maps a Banach space $(Lip[0,1], \|\cdot\|_{Lip[0,1]})$ of Lipschitzian functions $\varphi \in \mathbb{R}^{[0,1]}$ with the classical $Lip[0,1]$ -norm into itself and is globally Lipschitzian, i.e., if for some constant $c \geq 0$,

$$\|H(\varphi_1) - H(\varphi_2)\|_{Lip[0,1]} \leq c \|\varphi_1 - \varphi_2\|_{Lip[0,1]}, \quad \varphi_1, \varphi_2 \in Lip[0,1],$$

then

$$h(x, y) = \alpha(x)y + \beta(x), \quad x \in [0,1], \quad y \in \mathbb{R},$$

for some functions $\alpha, \beta \in Lip[0,1]$, i.e., h is an affine function with respect to the second variable. Analogous results for representations of the generators of globally Lipschitzian operators have been proved for some other function spaces. Later, it was observed that these results remain true if the Lipschitz norm-continuity of H is replaced by its uniform continuity.

In 2011, J. Matkowski proved, under very general assumptions, that for the function spaces including the Hölder spaces as a special case, the uniform continuity of the operator H can be replaced by a much weaker condition of the uniform boundedness (which is weaker than norm-boundedness).

The purpose of this paper is to show that if H maps the space $W_\gamma^n[a, b]$ of n -times differentiable functions with the n -derivative satisfying a generalized Hölder

condition into $W_\gamma^r[a, b]$, where $n \geq r$, and H is uniformly bounded, then the Matkowski representation holds.

Definition. Let X and Y be two metric spaces. We say that a mapping $F: X \rightarrow Y$ is *uniformly bounded* if, for any $t > 0$, there exists a real number $f(t)$ such that for any nonempty set $B \subset X$, we have

$$\text{diam}B \leq t \Rightarrow \text{diam}F(B) \leq f(t).$$

The main result of this paper reads as follows:

Theorem. Let $a, b \in \mathbb{R}, n, r \in \mathbb{N}, a < b, n \geq r$, be fixed and let a function $h: [a, b] \times \mathbb{R} \rightarrow \mathbb{R}$ be such that for any $x \in [a, b]$ the function $h(x, \cdot): \mathbb{R} \rightarrow \mathbb{R}$ is r -times differentiable and its r -th derivatives satisfy the Lipschitz condition on \mathbb{R} . If the composition operator H of the generator h maps the space $W_\gamma^n[a, b]$ into $W_\gamma^r[a, b]$, $n \geq r$, and is uniformly bounded, then there exist $\alpha \in W_\gamma^r[a, b]$ and $\beta \in W_\gamma^r[a, b]$ such that

$$h(x, y) = \alpha(x)y + \beta(x), \quad x \in [a, b], \quad y \in \mathbb{R}.$$

and

$$H(\varphi)(x) = \alpha(x)\varphi(x) + \beta(x), \quad \varphi \in W_\gamma[a, b], \quad (x \in [a, b]).$$

References

- [1] Appell J., Banaś J., Merentes N., Bounded Variation and Around, De Gruyter Studies in Non-linear Analysis and Applications, Volume 17, Würzburg 2014.
- [2] Appell J., Zabrejko P.P., Nonlinear Superposition Operators, Cambridge University Press, Cambridge-New York-Port Chester-Melbourne-Sydney 1990.
- [3] J. Knop, On globally Lipschitzian Nemytskii operator in a special Banach space of functions, Fasciculi Mathematici, 280 (21) (1990), 79-85.
- [4] M. Lupa, Form of Lipschitzian operator of substitution in some class of functions, Zeszyty Naukowe Politechniki Łódzkiej, Matematyka, 1990, 21, 87-96..
- [5] J. Matkowski, Uniformly continuous superposition operators in the space of Hölder functions, J. Math. Anal. App. 359 (2009), 56-61.
- [6] J. Matkowski, Uniformly continuous superposition operators in the spaces of bounded variation functions, Math. Nach. 283 (7) (2010), 1060-1064.
- [7] Matkowski, Uniformly bounded composition operators between general Lipschitz functions normed spaces, Topol. Methods Nonlinear Anal., 38(2) (2011), 395-406.
- [8] J. Matkowski, M. Wróbel, Uniformly bounded set-valued Nemytskij operators acting between generalized Hölder function spaces, Cent. Eur. J. Math. 10(2) (2012), 609-618.
- [9] M. Wróbel, Uniformly bounded Nemytskij operators between the Banach spaces of functions of bounded n -th variation, J. Math. Anal. Appl. 391 (2012), 451-456.

A FEW WORDS ABOUT SUPPLY AND DEMAND

Ewa Ładyga¹, Marek Ładyga²

*Institute of Mathematics, Czestochowa University of Technology,
Czestochowa, Poland
¹ewa.ladyga@im.pcz.pl, ²marek.ladyga@im.pcz.pl*

Keywords: **demand, supply, labor market, employment**

The demand and supply analysis on the university graduates labor market has been subjected to some tendencies for some time. It turns out that, currently, the graduates of technical faculties and exact sciences find the job the fastest. However, the condition is to have appropriate soft competences, such as creativity, self-management in time, communicative skills or the ability to work in a team. The employers reported a deficit for employees with technical and exact education without indicating the field of study. It played a lesser role, because the attention was paid to competences in the form of knowledge of specialist software and the above-mentioned soft skills [1].

A certain challenge for the university is the need to match the skills and competences of students studying to the needs of the labor market. It turns out that adaptation of the educational offer through the creation of new fields of study is not a good trend, due to the rapid changes on the labor market. A good solution would be the introduction of specific content, to the existing fields of study and specializations, shaping the competencies that allow adapting the acquired knowledge to the conditions of the work undertaken. The weakness of the education and training market requires a better adaptation of the demand and supply of skills and competences of both, graduates undertaking work and training of people already employed, in order to raise their knowledge and skills.

In Poland, there is an increase in supply for high qualifications. Graduates of higher education schools supply the labor market, often undertaking a job that is not necessarily consistent with the obtained education. The number of people employed in the services and trade sphere is growing. Employers increase the demand for skills at the highest level, taking into account the technological changes and economic trends taking place on the market [2].

Therefore, it is necessary to recognize the real situation of university graduates in the labor market. The graduate's transition stage to the labor market has been controlled by universities since 2011. The obligation to monitor the professional

life of graduates by universities was introduced by the Ministry of Science and Higher Education in order to adapt fields of study to the needs of the labor market [3].

At the Czestochowa University of Technology reports from the survey conducted among graduates, have been developed. The surveys were anonymous, carried out three times - after the end of education, then after three and five years from the date of graduation. Based on surveys conducted in 2012, 2013, 2014 and 2015, it was found that almost half of the graduates undertake work incompatible with their education, about 60% of respondents admitted that they had a job at the time of graduation. It was important to assess the level of own competences in relation to the competencies required by the employer. The level of competence in analytical and logical thinking was 15% at the higher level, 65% at the appropriate level; the ability to work effectively in a group - 18% at a higher level, 61% of indications at the appropriate level; ability to organize work independently - 19% higher competences, 59% appropriate ones [4].

The employers' forecasts regarding the employment of graduates by educational areas and voivodships by 2020 for the silesian voivodeship are presented as follows:

- employment growth in the field of exact sciences at 40% (34% on average in the country)
- 77% in technical science (71% on average in the country).

For comparison, on average in the country in the area of humanities it is planned to increase employment by 4%, 28% in the area of social sciences, 16% medical and health sciences, 5% natural sciences and 1% in the field of art [1].

On the basis of the mentioned studies, it can be concluded that graduation from higher education still increases the chances of employment. However, due to the excess supply of graduates over the demand on the labor market, graduates must demonstrate greater competitiveness over the people with lower education. Employers can offer worse working conditions and pay and positions that do not require higher education [3].

Universities, for their part, strive for the highest quality of education in order provide to graduates a range of competences guaranteeing success on the labor market.

References

- [1] Analiza kwalifikacji i kompetencji kluczowych dla zwiększenia szans absolwentów na rynku pracy, Raport końcowy Narodowego Centrum Badań i Rozwoju, Warszawa, 2014.
- [2] Chłoń-Domińczak, A., Kamieniecka, M., Trawińska-Konador, K., Pawłowski, M. i Rynko, M. Popyt na kompetencje i kwalifikacje oraz ich podaż – wnioski z badań, Instytut Badań Edukacyjnych, Warszawa, 2015.
- [3] Piróg, D., Absolwenci szkół wyższych na rynku pracy w warunkach kryzysu, Przedsiębiorczość – Edukacja, Kraków, 2013.
- [4] Węgrzyn-Skrzypczak, E., Szota, K., Tuzikiewicz, W., Raport z przeprowadzenia ankiety dla absolwentów kończących studia na WIMiI, Politechnika Częstochowska, 2013, 2014, 2015.

**METHODS OF MULTIDIMENSIONAL COMPARISON ANALYSIS
IN ENTERPRISE MANAGEMENT**

Marek Ładyga¹, Ewa Ładyga²

*Institute of Mathematics, Czestochowa University of Technology,
Czestochowa, Poland*

¹marek.ladyga@im.pcz.pl, ²ewa.ladyga@im.pcz.pl

Keywords: investment quality indicator, linear object organization

Investment quality indicator is defined in papers [1]. Its properties are presented in paper [2]. It was applied for the research of investment in capital enterprises on annual or multiannual scale. Based on some properties of this indicator the potential client, by comparison of indicators from many enterprises, had a chance to make a choice of the enterprise which suits him the best. This article has the main aim to present the basic methods of multidimensional comparison analysis for research about efficiency of managing and management enterprises from certain branch. Quality indicator analysis also allows for choosing adequate management and planning strategy of chosen enterprise development. Basic and undefined concepts of comparison analysis are concepts of object variable. In this case the enterprise is the object and investment quality indicators are variables. Let suppose that we investigate the m enterprise, which is beginning investments for n years. The annual investment quality indicator for enterprise r ($r = 1, \dots, m$) in year k is specified as

$$I_{rk} = \frac{1 + a_{rk}}{1 + i_k}, \quad k = 1, \dots, n \quad (1)$$

where

a_{rk} – rate of profit for enterprise r in year k

i_k – inflation in year k .

Now the variable values (investment quality indicators) we can sign up in the form of so called observation matrix I

$$I = \begin{bmatrix} I_{11} & I_{12} & \dots & I_{1n} \\ I_{21} & I_{22} & \dots & I_{2n} \\ \dots & \dots & \dots & \dots \\ I_{m1} & I_{m2} & \dots & I_{mn} \end{bmatrix} \quad (2)$$

In case when analysis of enterprises from different branches is made, it is necessary to perform the appropriate regulation of observation matrix. There is many manners for this regulation. The most common way is standardization. It rest on replacement I_{rk} variable by variable

$$Z_{rk} = \frac{i_{rk} + \bar{I}_k}{S_k} \quad (3)$$

where

$$\bar{I}_k = \frac{1}{m(1+i_k)} \sum_{r=1}^m (1+a_{rk}) \quad (4)$$

$$S_k = \sqrt{\frac{1}{m} \sum_{r=1}^m (I_{rk} - \bar{I}_k)^2} \quad (5)$$

where S_k is a standard deviation of variable k .

But the easiest method for regulation of observation matrix is replacement I_{rk} variable by variable

$$Z_{rk} = \frac{I_{rk} - \min_r I_{rk}}{t_k} \quad (6)$$

where

$$t_k = \max_r I_{rk} - \min_r I_{rk} \quad (7)$$

This dimension in comparison analysis is called dispersion or interval variable k . The standard deviation the same as interval variable k might be, in some cases, the illustration of profitability in compared enterprises. For example high differentiation t_k also means high differentiation of enterprises profits. However, these parameters do not give the criteria for choosing enterprises in view of probability.

This paper presents the comparison analysis of enterprises (objects) from the same branch. So the regulation of observation matrix is not necessary.

One of basic concepts, allowing for object comparison in respect of investigated phenomenon, is their 'resemblance', which measure is distance between them. Most commonly used formulas for distance between object i and object j are

a) Euclidean distance

$$d_{ij} = \sqrt{\sum_{k=1}^n (I_{ik} - I_{jk})^2} = \sqrt{\sum_{k=1}^n \left(\frac{a_{ik} - a_{jk}}{1+i_k} \right)^2} \quad (8)$$

b) New York distance

$$d_{ij} = \sum_{k=1}^n |I_{ik} - I_{jk}| = \sum_{k=1}^n \frac{|a_{ik} - a_{jk}|}{1 + i_k} \quad (9)$$

By calculating distances for all pairs of objects we receive the distance matrix

$$D = \begin{bmatrix} D_{11} & D_{12} & \dots & D_{1m} \\ D_{21} & D_{22} & \dots & D_{2m} \\ \dots & \dots & \dots & D_{3m} \\ D_{m1} & D_{m2} & \dots & D_{mm} \end{bmatrix} \quad (10)$$

From term d_{ij} immediately results $d_{ii} = 0$ and $D = D^T$. Distance between objects is the measure of their differentiation, so if the distance between objects – enterprises is smaller than their profits are more similar.

Other basic problem, which is solving by methods of comparison analysis, is linear object organization. It rest on designation the bijection f , which for each object from certain objects set $A(\overline{A} = m)$ assigns natural number from set $\{1, 2, \dots, m\}$ so as $f(O_i) > f(O_j)$. Than it means that object O_i is characterized by higher level of phenomenon than object O_j . One of methods of linear organization is the method of pattern development (standard object). It consists of three stages. In first stage, it is necessary to determine standard object O_w .

$$O_w = [I_{w1}, I_{w2}, \dots, I_{wm}] \quad (11)$$

where

$$I_{wi} = \max(I_{1i}, I_{2i}, \dots, I_{mi}), \quad i = 1, 2, \dots, n \quad (12)$$

Assuming that each variable I_{jk} is stimulant, in the case when I_{jk} is destimulant, than in above formulas should be adopted minimum. Besides, in general case, it is necessary to consider the standardized observation matrix. In second stage, there are determining distances between each object and standard object by formula

$$d_{ij} = \sqrt{\sum_{j=1}^n (I_{wj} - I_{ij})^2}, \quad i = 1, 2, \dots, m \quad (13)$$

And then (in the third stage) for each object there are determining so called development measures

$$m_i = 1 - \frac{d_{wi}}{d_w}, \quad i = 1, 2, \dots, m \quad (14)$$

where

$$d_w = \sqrt{\sum_{j=1}^n (I_{wj} - I_{wj}^-)^2} \quad (15)$$

however

$$I_{wj}^- = \min(I_{1i}, I_{2i}, \dots, I_{mi}), \quad i = 1, 2, \dots, n \quad (16)$$

If I_{jk} is destimulant then in above formulas it is necessary to adopt the maximum instead minimum. The objects are organized by development measures. It is easy to notice that if the value of development measure is higher, the level of phenomenon is higher too.

The above methods might be also used for profits comparison in m enterprises in monthly cycles during one year period. The investment quality indicator, which in this case might be regarding as profitability indicator for enterprise r ($r = 1, 2, \dots, m$) in month k , would have identical form as annual investment quality indicator, i.e.

$$I_{rk} = \frac{1 + a_{rk}}{1 + i_k}, \quad k = 1, 2, \dots, 12 \quad (17)$$

where:

a_{rk} – rate of profit for enterprise r in month k of given year

i_{rk} – inflation in month k of given year.

References

- [1] Ładyga M., Tkacz M., Ogólna analiza składek w ubezpieczeniach mieszanych, Sympozium Naukowe Instytutu Matematyki i Informatyki, Poraj 2000, 79-82 (in Polish).
- [2] Ładyga M., Tkacz M., Indeksnyj metod ofienki inwestycji. Menedżment: Teorja I praktika rjeszenija ostrasliewnych i regionalnych problem. Sbornik naucznych trudow. Moskwa 2015. (in Russian)
- [3] Ładyga M., Tkacz M., The method of balancing the production and consumption model in the case of indivisible articles, Journal of Applied Mathematics and Computational Mechanics, 12(4), 2013, 83-88.
- [4] Ładyga M., Tkacz M., The properties of method balancing the unsustainable production and consumption model, Scientific Research of the Institute of Mathematics and Computer Science 2012, 3(11), 105-109.

**APPLICATION OF NUMERICAL METHODS FOR SOLVING THE
NON-FOURIER EQUATIONS. REVIEW OF OWN AND
COLLABORATORS WORKS**

Ewa Majchrzak¹, Bohdan Mochnacki²

¹*Institute of Computational Mechanics and Engineering, Silesian University of Technology, Gliwice,
Poland*

²*University of Occupational Safety Management in Katowice, Katowice, Poland*
¹*ewa.majchrzak@polsl.pl, ²bmochnacki@wszop.edu.pl*

Keywords: heat transfer, non-Fourier heat diffusion models, numerical methods, computational mechanics

Thermal processes occurring in the solid bodies are, as a rule, described by the well known Fourier equation (or the system of these equations) supplemented by the appropriate boundary and initial conditions. Such a mathematical model is sufficiently exact to describe the heat transfer processes in the macro scale for the typical materials. It turned out, that the energy equation based on the Fourier law has the limitations and it should not be used in the case of the microscale heat transfer and also in the case of materials with a special inner structure (e.g. biological tissue). The better approximation of the real thermal processes assure the modifications of the energy equation, in particular the models in which the so-called lag times are introduced. The article presented is devoted to the numerical aspects of solving this type of equations (in the scope of the microscale heat transfer). The results published by the other authors can be found in the references posted in the works cited below.

References

- [1] Ciesielski, M. (2017). Analytical solution of the dual phase lag equation describing the laser heating of thin metal film, *Journal of Applied Mathematics and Computational Mechanics*, 16 (1), 33-40.
- [2] Majchrzak, E. & Mochnacki, B. (2016). Dual-phase lag equation. Stability conditions of a numerical algorithm based on the explicit scheme of the finite difference method, *Journal of Applied Mathematics and Computational Mechanics*, 15 (3), 89-96.
- [3] Mochnacki, B. & Tuzikiewicz, W. (2016). Cattaneo-Vernotte bioheat transfer equation. Stability conditions of numerical algorithm based on the explicit scheme of the finite difference method, *Journal of Applied Mathematics and Computational Mechanics*, 15 (4), 137-144.
- [4] Majchrzak, E. & Mochnacki, B. (2017). Implicit scheme of the finite difference method for 1D dual-phase lag equation, *Journal of Applied Mathematics and Computational Mechanics*, 16 (3), 37-46.
- [5] Majchrzak, E. & Mochnacki, B. (2018). Implicit scheme of the finite difference method for the second-order dual phase lag equation, *Journal of Theoretical and Applied Mechanics*, 56 (2), 393-402.

- [6] Mochnacki, B. & Ciesielski, M. (2017). Numerical solution of the dual phase lag equation using the control volume method and Crank-Nicolson scheme, ECCOMAS MSF Thematic Conference, Ljubljana, Slovenia, 196-199.
- [7] Ciesielski, M. (2017). Application of the alternating direction implicit method for numerical solution of the dual phase lag equation, *Journal of Theoretical and Applied Mechanics*, 55 (3), 839-852.
- [8] Majchrzak, E., Mochnacki, B. & Suchy, J. S. (2009). Numerical simulation of thermal processes proceeding in a multi-layered film subjected to ultrafast laser heating, *Journal of Theoretical and Applied Mechanics*, 47 (2), 383-396.
- [9] Majchrzak, E., Mochnacki, B., Greer A. L. & Suchy, J. S. (2009). Numerical modeling of short pulse laser interactions with multi-layered thin metal films, *Computer Modeling in Engineering and Sciences*, 41, 2, 131-146.
- [10] Majchrzak, E. & Kałuża, G. (2017). Analysis of thermal processes occurring in the heated multilayered metal films using the dual-phase lag model, *Archives of Mechanics*, 69, 4-5, 275-287.
- [11] Turchan, Ł. (2017). Solving the dual-phase lag bioheat transfer equation by the generalized finite difference method, *Archives of Mechanics*, 69, 4-5, 389-407.
- [12] Majchrzak, E. & Mochnacki, B. (2017). Numerical model of thin metal film heating using the boundary element method, *Computer Methods in Materials Science*, 17, 1, 12-17.
- [13] Mochnacki, B. & Ciesielski, M. (2016). Dual phase lag model of melting process in domain of metal film subjected to an external heat flux, *Archives of Foundry Engineering*, 16, 4, 85-90.
- [14] Ciesielski, M., Duda, M. & Mochnacki, B. (2016). Comparison of bio-heat transfer numerical models based on the Pennes and Cattaneo-Vernotte equations, *Journal of Applied Mathematics and Computational Mechanics*, 15, 4, 33-38.
- [15] Mochnacki, B. & Majchrzak, E. (2017). Numerical model of thermal interactions between cylindrical cryoprobe and biological tissue using the dual-phase lag equation, *International Journal of Heat and Mass Transfer*, 108, 1-10.
- [16] Kałuża, G., Majchrzak, E. & Turchan Ł. (2017). Sensitivity analysis of temperature field in the heated soft tissue with respect to the perturbations of porosity, *Applied Mathematical Modelling*, 49, 498-513.
- [17] Majchrzak, E., Jasiński, M. & Turchan Ł. (2017). Modeling of laser-soft tissue interactions using the dual-phase lag equation: sensitivity analysis with respect to selected tissue parameters, *Defect and Diffusion Forum*, 379, 108-123.

THE ADVANTAGES OF LINEAR LOGIC IN COMPUTER SCIENCE

Valerie Novitzká, William Steingartner, Mohamed Ali M. Eldojali

*Faculty of Electrical Engineering and Informatics, Technical University of Košice,
Košice, Slovakia*

valerie.novitzka@tuke.sk, william.steingartner@tuke.sk, eldojalimohamed@gmail.com

Abstract. Linear logic has become one of the perspective logical systems available for computer science. It enables to express causality, dynamics of processes, internal and external non-determinism. Each of linear formula can be considered as an action or as a resource. We show on a simple example how Petri nets can be transform to linear formulas.

Keywords: **linear logic, Petri nets, mutual exclusion**

1. Introduction

The logical systems play an important role in development of modern software systems. In present, the mostly used logics are propositional and predicate logic, but in the recent years also some kinds of modal logics have found their applications in software engineering. In this paper, we concern on the one of the non-classical logics, the linear logic, that seems to be useful for applications in computer science.

Linear logic was introduced by J. Y. Girard in 1987 [4]. The first aim of the author was to extend the classical propositional and predicate logic with new logical connectives and to introduce dynamics into logic. During the last years, the linear logic has become a new perspective logical system that can work with actions and resources [5]. Because it considers as the resources time and space (memory), its usefulness grows especially in computer science. The another advantage of linear logic is its possible fragmentation according to solved problem and its intuitionistic version that is a subject of Curry-Howard correspondence [15]. Linear logic can be extended also by special operators from some of modal logics, e.g. standard modal logic, epistemic logic, what increases its expressive power [7,11].

The aim of this paper is to advertise several interesting features of linear logic and its possible applications in computing science. For simplicity, we consider only propositional linear logic in this paper. The second section contains a short introduction to linear logic with special emphasis on its logical connectives, its modal operators and on its static and dynamic nature. In the third section we discuss our view of the fragments of linear logic that can serve for different purposes in various areas of computer science. The fourth section contains a short

description of possible application of linear logic in specifying a real program system.

2. Basic Concepts of Linear Logic

In this section we introduce the basic notions of linear logic. Linear formulas are denoted by capital letters A, B, C, \dots . Each formula expresses an action or a resource [6]. From the elementary formulas we can construct more complex ones using logical connectives. We shortly characterize them in the following text.

The most interesting logical connective of linear logic is linear implication. A formula

$$A \multimap B$$

introduces dynamics into linear logic. If we consider A, B as actions, or processes, then this implication expresses sequentiality of these actions, a process B follows after a process A ends. We can say that an action A is a cause of an action B . In case, where A, B are resources, it means that a resource A is consumed after implication. This property of linear implication enables to describe sequential processes and/or consumption of resources, that means, a process/resource A is no more valid after linear implication.

Linear logic has two conjunctions, multiplicative one, \otimes , and additive one, $\&$. The multiplicative conjunction

$$A \otimes B$$

expresses that the both actions A, B are executed simultaneously. That means, linear logic enables to express parallelism of processes. In case A, B are resources, it expresses that both resources are available at once. Therefore the number of assumptions is significant in linear logic. Additive conjunction

$$A \& B$$

expresses that one of the actions can be executed and we can predict from an environment which one. In case of resources, we have one of them and we can deduce which one. Therefore we can say that by additive conjunction we can describe external non-determinism.

Similarly, linear logic has two disjunctions, multiplicative one, \wp and additive one, \oplus . The formula

$$A \wp B$$

means: if A is not executed then B is executed and vice versa. It works similarly as the instruction xor. The formula

$$A \oplus B$$

expresses that only one of these formulas A, B can be executed but we do not predict which one. Therefore we can say that additive disjunction enables to specify internal non-determinism.

Linear negation is a unary logical connective and a formula

$$A^\perp$$

expresses that an action is done or a resource is consumed. Linear negation is involutive, i.e. $A^{\perp\perp} \equiv A$.

Instead of traditional logical systems, where are two truth values, true and false, linear logic has four neutral elements, for each logical operation of conjunction and disjunction.

Linear logic has two modal operators that indicate unexhaustive resources, or repeated execution of actions. A formula $!A$ denotes that a resource is available infinitely, or that an action is iteratively executed. The second modal operator expresses a potential unexhaustibility of a resource or infinitely executed action. For instance, a classical implication $A \Rightarrow B$ can be transformed to linear implication $!A \multimap B$. The second modal operator is $?$, it expresses a potentially unexhaustive resource. These modal operators are dual.

The semantics of linear logic was defined by Girard in terms of phase spaces. The new approaches use as models SMCC categories [1, 13,14] or *-categories [3]. The main principle in defining semantics of linear logic is that a formula can be represented as a type. The deduction calculus of linear logic is defined as a sequent calculus. A sequent has a form

$$\Gamma \vdash A,$$

where Γ is a set of linear formulas called assumptions and A is a set of linear formulas that can be inferred from the assumptions. The main principle is that a number of assumption is significant, therefore the known deduction rules of weakening and contractions cannot be used. The whole sequent calculus is in [9].

3. Possibilities of Linear Logic and their Fragments

Linear logic can be used as a tool for specifying various kinds of program systems. Frequently, we need to use only a part of this large logical apparatus. In such cases we can consider some fragments of linear logic [8].

When we consider only multiplicative conjunction and disjunctions, we say, that we use multiplicative fragment of linear logic. This fragment is sometimes called intensional fragment, because the semantics of the formulas is defined as sense or non-sense.

When we consider additive conjunctions and disjunctions, we use additive fragment of linear logic, or in other words, extensional fragment, where formulas have a meaning true or false.

The fragment using only multiplicative connectives is a multiplicative fragment and it corresponds with product types in linear type theory. The fragment, which consider only additive ones is an additive fragment and it corresponds with sum (coproduct) types in linear type theory.

The logical connectives of linear implication and linear negation are neutral, i.e. we can use them in any fragment of linear logic mentioned above.

For handling resources, we need another properties of logical connectives in linear logic called polarity [10]. We say that the fragment of linear logic is positive, if the formulas are constructed only by using the following connectives with positive polarity: \otimes , \oplus , $!$. The fragment of linear logic is negative, if the formulas are constructed only by using connectives with negative polarity: $\&$, \wp , $?$. The polarity can be turned over by negation $(\)^\perp$. That means, if a formula is positive, its negation is negative and vice versa. Linear implication as the whole is neutral, but after it, the polarity of implication premise is changed.

The last possible fragment of linear logic is intuitionistic linear logic [2], that uses all linear connectives excluding multiplicative disjunction \wp . The main difference is in deduction calculus, where the sequents can have only one formula on the right-hand side of a sequents. Certainly, the intuitionistic fragment does not use absurdum proof. But the advantage of intuitionistic fragment of linear logic is that it corresponds with typed λ -calculus with linear terms.

4. Description and Modelling of Systems using Linear Logic

Linear logic is a useful logical system for describing and verifying real program systems. In this section we demonstrate its possibilities and advantages for modelling synchronization problem [12].

The known formal tool for modeling the synchronization problem of concurrent systems are Petri nets (PN). A PN can be illustrated as a graph that has two types of nodes: places and transitions. The places represent possible states of a system and the transitions represent changes of states, i.e. events. The places can contain special marks called tokens. A transition is enabled, i.e. it can be fired, if there is a required number of tokens in places on input arcs. When a transition is fired, it produces tokens in all places on the output arcs. Generally, execution of a PN is nondeterministic: when more than one transition is enabled, any of them can be fired. Any distribution of tokens over places represents a configuration of a given PN called marking. For any place p of a PN, its marking is a function $m: P \rightarrow \mathbb{N}_0$ returning a number of tokens in p . \mathbb{N}_0 denotes the set of natural numbers with zero. A marking of a PN is defined as a tuple

$$m = (m(p_1), \dots, m(p_n))$$

of markings of all places in a PN. When a transition t is fired, a token from each input place is deleted and to each output place is added a token.

A *behavior* of a PN can be observed as a sequence of markings reached during execution of a PN. We define the transformations of some significant patterns of

PNs, to corresponding sequents of linear formulas. A place p of a PN containing one token, i.e. with the marking $m(p) = 1$, we denote by the elementary proposition p of linear logic. Marking expresses that a place p_1 contains one token and a place p_2 contains two tokens, can be denoted using multiplicative conjunction:

$$p_1 \otimes p_2 \otimes p_2.$$

For describing a transition of PN by a linear formula, we use linear implication \multimap , where the premise is a marking making a transition t to be enabled and the conclusion is a marking after firing of t . Linear implication expresses change of states caused by firing a transition together with the consumed resources (tokens) on the left-hand side and the produced resources (tokens) on the right-hand side of implication [4]. For instance, if t is a transition that can be fired when the places p_1 and p_2 both have one token and after firing t the place p_3 obtains a token, then this transition can be denoted by the following linear implication:

$$t \equiv p_1 \otimes p_2 \multimap p_3.$$

A behavior of a PN we describe by the sequents of linear logic in the form:

$$m, l \vdash m',$$

where

- m is a marking before firing a transition,
- l is a list of enabled transitions expressed by linear implications defined above, and
- m' is a marking after firing a transition.

Such sequents express that from a marking m by firing a transition from l the marking m' is produced.

Now we consider the PN in Fig. 1. It models the well-known problem of mutual exclusion (mutex). The principle of mutex is that only one of the processes can be executed in one moment. Let the initial marking be $m_0 = (1,0,1,0,1)$. After the transformation of this PN to linear sequent, we can describe the behavior of mutex as follows:

$$p_1, p_3, p_5, ((p_3 \otimes p_5) \multimap p_4) \oplus ((p_1 \otimes p_3) \multimap p_2) \vdash (p_4 \otimes p_1) \& (p_2 \otimes p_5),$$

where on the left-hand side we use internal nondeterminism, i.e. additive disjunction \oplus between transitions t_2 and t_1 . On the right-hand side of this sequent we use additive conjunction $\&$ between tokens because they depend on which of

the transitions t_2 and t_1 was actually fired. Provability of this sequent ensures that we have a solution of mutual exclusion.

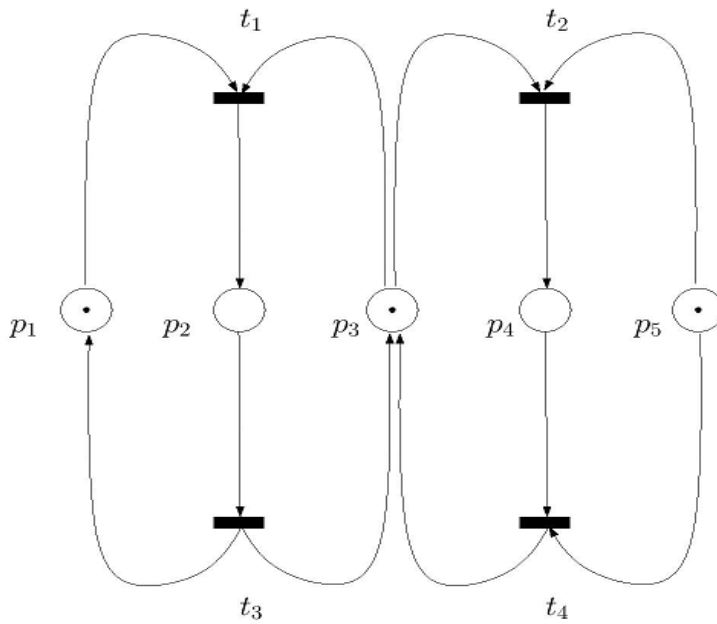

Fig. 1 Petri net for mutual exclusion

5. Conclusion

In this paper, we have tried to present a short overview to one perspective logical system, linear logic. It enables to express dynamics, causality, non-determinism, and parallelism. It can work with resources as are time and space. Therefore this system is useful in computer science for describing real program systems in provable manner.

Acknowledgments

This work has been supported by the Slovak Research and Development Agency under the contract No. SK-AT-2017-0012: Semantics technologies for computer science education.

References

- [1] Ambler, S.J.: First order linear logic in symmetric monoidal closed categories, PhD. Thesis, University of Edinburgh, 1991.
- [2] Bierman, G.: On intuitionistic linear logic, University of Cambridge, 1994.
- [3] Blute, R. Scott, P.: Category theory for linear logicians, In: Linear Logic Summer School, Cambridge Univ. Press, 2003.
- [4] Girard J.-Y.: Linear Logic, Theoretical Computer Science, Vol. 50, 1987, pp. 1-102.
- [5] Girard J.-Y.: P. Taylor, Y. Lafont, Proofs and Types, Cambridge University Press, New York, NY, USA, 1989.
- [6] Girard J.-Y.: Linear Logic: its syntax and semantics, Cambridge University Press, 2003.
- [7] Mihályi D., Novitzká V.: Towards to the Knowledge in Coalgebraic Model of IDS, Computing and Informatics, 2012.
- [8] Mihályi D., Novitzká V.: What about linear logic in computer science?, Department of Computers and Informatics, Technical University of Košice, Acta Polytechnica Hungarica, Vol. 10, No. 4, 2013, pp. 147-160.
- [9] Novitzká, V., Mihályi, D., Slodičák, V.: Linear logical reasoning on programming, Acta electrotechnica et Infomatica, Vol.6, No.3, 2006, pp.34-39.
- [10] Novitzká V., Mihályi D.: Resource-oriented programming based on linear logic, Acta Polytechnica Hungarica, Vol. 4, No.2, 2007, pp. 157-166.
- [11] Perháč J., Mihályi D.: Intrusion Detection System Behavior as Resource-Oriented Formula, Acta Electrotechnica et Informatica. Vol. 15, No. 3, pp. 9-13, 2015
- [12] Perháč J., Mihályi D., Novitzká V.: Modeling synchronization problems, Acta Polytechnica Hungarica, Vol.4, No.8, 2017, pp.165-182.
- [13] Slodičák, V.: Toposes are symmetric monoidal closed categories, Scientific Research of the Institute of Mathematics and Computer Science, Vol. 11, No. 1, pp. 107-116, 2012, The publishing Office of Czestochowa University of Technology, Czestochowa, Poland
- [14] Slodičák, V.: Some Useful Structures for Categorical Approach for Program Behavior, Journal of Information and Organizational Sciences, Vol. 35, No. 1, 2011, pp. 99-109.
- [15] Sorensen, M.H., Urczyczyn, P.: Lectures on the Curry-Howard isomorphism, DIKU Report 98/14, 1998.
- [16] Steingartner W., et al.: Linear logic in computer science, Journal of Applied mathematics and computational mechanics, Vol. 4, No. 1, 2015, pp. 91-100, The publishing Office of Czestochowa University of Technology, Czestochowa, Poland

**FRACTIONAL HEAT CONDUCTION AND DIFFUSION
EQUATIONS AND ASSOCIATED THEORIES OF THERMAL AND
DIFFUSIVE STRESSES**

Yuriy Povstenko

*Institute of Mathematics and Computer Science, Jan Dlugosz University in Czestochowa,
Czestochowa, Poland
j.povstenko@ajd.czyst.pl*

Keywords: **thermal stresses, diffusive stresses**

Many theoretical and experimental studies of transport phenomena testify that in solids with complex internal structure the classical Fourier law and Fick law are no longer accurate enough. This leads to formulation of nonclassical theories in which the standard heat conduction and diffusion equations are replaced by more general equations. Each generalization of the heat conduction equation or the diffusion equation leads to the corresponding generalization of the theory of thermal or diffusive stresses. The theories of thermal and diffusive stresses based on fractional heat conduction and diffusion equations [1] are discussed.

References

[1] Povstenko Y., Fractional Thermoelasticity, Springer, New York 2015.

THE INFLUENCE OF THE BOUNDARY CONDITIONS ON THE SHEAR STRESSES IN SANDWICH PANELS SUBJECTED TO TORSION

Zbigniew Pozorski¹, Szymon Wojciechowski²

¹*Institute of Structural Engineering, Poznan University of Technology, Poland*

²*Institute of Structural Engineering, Poznan University of Technology, Poland*

¹*zbigniew.pozorski@put.poznan.pl, ²szymon.kr.wojciechowski@doctorate.put.poznan.pl*

Keywords: sandwich panels, torsion, numerical simulations, boundary conditions, St. Venant’s torsion, Vlasov torsion

A typical sandwich panel has a three-layered structure. The rigid faces with a relatively high modulus of elasticity are kept apart by the much lighter core which has a shear stiffness sufficient to carry most of shear forces [1]. The composite structural element has significant capacity to carry out forces that are perpendicular to their faces. However, more and more often there is a necessity to apply to the sandwich panels a load eccentrically (Fig. 1). This situation could take place in the constructions which are created by using sandwich panels assembled in horizontal position (e.g. building envelopes – walls). An eccentricity of load application induces torsion of the sandwich element (Fig. 1).

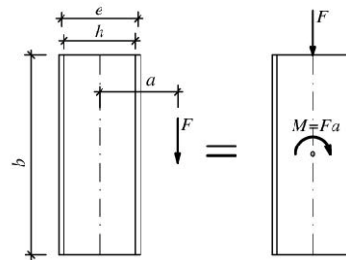

Fig. 1. The cross-section of horizontal sandwich panel with additional eccentric loading inducing torsion of the element [2].

The aim of this paper is to present the numerical simulation of the influence of the boundary conditions on the shear stresses in sandwich panels subjected to torsion. The 3D numerical models created in SIMULIA Abaqus are considered very carefully and the solutions are compared with the results obtained using the St. Venant’s torsion theory [4] and Vlasov torsion theory [3].

The simplified 1D model used to analytical calculations of internal stresses and strains (using formulas presented in [3] and [4]) is shown in Fig. 2b. It is one of the

basic static systems of beams subjected to torsion. At the both ends it has a fork support, it means – the angle of rotation of the cross-section is blocked, but there is still freedom of warping (deplanation) of the cross-section [2]. The beam is subjected to a single torsional moment M . When it comes to the 3D, the numerical models (Fig. 2a) are considered for several kinds of boundary conditions. The first of them was created as the most similar to 1D model. Then the support conditions were changed. The single torsional moment M in 3D models was defined by application of the uniform, tangential to the facings load, distributed over the middle band of both facings (the directions of the loads on the both facings are opposite).

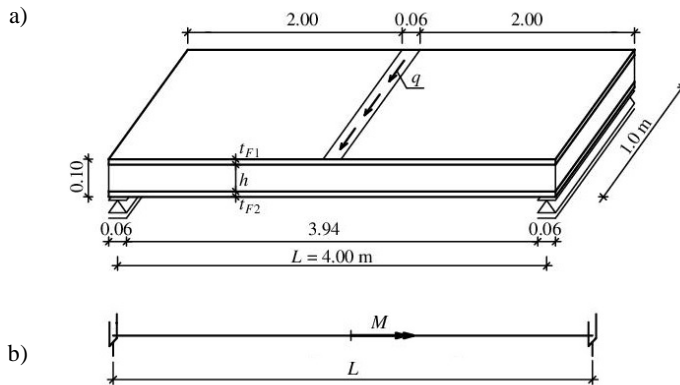

Fig. 2. Models of sandwich panel subjected to torsion: a) 3D sandwich structure, b) static scheme of the 1D element.

The thickness of the facings is equal to $t = 0.5$ mm. The parameters of the material of facings are: modulus of elasticity $E_F = 210$ GPa, Poisson's ratio $\nu_F = 0.3$. The thickness of the core is equal to $d = 99.0$ mm. Shear modulus of the core is $G_C = 3.5$ GPa.

Comparing results obtained using 3D numerical models with variable support conditions, some discrepancies can be seen. The internal stresses and strains in sandwich element reach divergent values. Boundary conditions in 3D numerical simulations are of great importance.

References

- [1] Davies J.M., *Lightweight Sandwich Construction*, Blackwell Science, Manchester, 2001
- [2] Pozorski Z., *Numerical analysis of sandwich panels subjected to torsion*, Selected Topics in Contemporary Mathematical Modeling, Czestochowa University of Technology, Czestochowa, 2017
- [3] Rutecki J., *Wytrzymałość konstrukcji cienkościennych*, Państwowe wydawnictwo naukowe, Warszawa, 1957
- [4] Stamm K., Witte H.: *Sandwichkonstruktionen. Berechnung, Fertigung, Ausföhrung.*, Springer-Verlag, Wien, New York, 1974

CONVERGENCE OF THE SEQUENCES OF HOMOGENEOUS YOUNG MEASURES

Piotr Puchała

*Institute of Mathematics, Czestochowa University of Technology,
Czestochowa, Poland
piotr.puchala@im.pcz.pl*

Keywords: homogeneous Young measures, weak convergence of functions, weak convergence of measures, density of a Young measure

Young measures appear in the calculus of variations while considering nonconvex optimization problems. We look for the infimum of the bounded from below functional of the form

$$J(v) = \int_{\Omega} f(x, v(x), \nabla v(x)) dx, \quad (1)$$

where:

- Ω is an open, bounded subset of \mathbb{R}^n with sufficiently smooth boundary;
- v is an element of a suitable (usually Sobolev) space V of functions on Ω with values in \mathbb{R}^m ;
- $f: \Omega \times \mathbb{R}^n \times \mathbb{R}^{mn} \rightarrow \mathbb{R} \cup \{+\infty\}$ is assumed to satisfy suitable regularity and growth conditions.

This problem has also physical interpretation, used for example in nonlinear elasticity. In this case the terms in equation (1) are looked at as:

- Ω is elastic body under consideration;
- v is its displacement;
- f is the density of the internal energy
- J is the energy functional.

It turns out that when f does not satisfy certain convexity conditions, the weak* convergence of the minimizing sequence (v_n) to the function v_0 does not guarantee, in general, that the weak* limit of the sequence $(f(x, v_n(x), \nabla v_n(x)))$ is equal to $(f(x, v_0(x), \nabla v_0(x)))$. This is caused by the lack of the convexity (more precisely: quasiconvexity – the notion introduced to take into consideration the principle of the material frame indifference in engineering applications) with respect to the third variable of the integrand f . The elements of the sequences minimizing the functional J are the functions of the highly oscillatory nature and considered functional, although bounded from below, does not attain its infimum.

In engineering we meet this situation, among others, when f is the density of the internal energy of laminates or various types of alloys.

Laurence Chisholm Young proved in [6] that the weak* limits of the sequences of the form mentioned above are in general families of probability measures, nowadays called the *Young measures*.

The simplest form of a Young measure is a ‘homogeneous Young measure’. It is in fact a ‘one parameter family’, i.e. it does not depend on points of Ω . It serves as a source of examples and in many real world cases, see for example [2] and [5].

Young measures can be regarded as the elements of the Banach space of measures with total variation norm. In the talk we take this point of view and focus our attention on the homogeneous Young measures with densities. Presented result are generalizations of those published in [3] and [4]. First we introduce the notion of a (not necessarily homogeneous) Young measure. Next we show that the weak convergence of the sequences of the homogeneous Young measures is closely related with the weak (in the space of integrable functions) convergence of their densities. Moreover, it turns out that the weak limit is also a homogeneous Young measure with density, which is not always the case.

References

- [1] Florescu, L. C, Godet-Thobie C., Young measures and compactness in measure spaces, Walter de Gruyter GmbH & Co. KG, Berlin, Boston, 2012.
- [2] Müller S., Variational models for microstructure and phase transitions, in Calculus of Variations and Geometric Evolution Problems, S. Hildebrandt and M. Struwe, editors, Lecture Notes in Mathematics, Vol. 1713, Springer Verlag, Berlin, Heidelberg, Germany, 1999, 85-210.
- [3] Puchała P., An elementary method of calculating an explicit form of Young measures in some special cases, Optimization 2014, vol. 63 No.9, 1419-1430.
- [4] Puchała, P., A simple characterization of homogeneous Young measures and weak convergence of their densities, Optimization 2017, vol. 66 No.2, 197-203.
- [5] Roubíček T., Relaxation in Optimization Theory and Variational Calculus, Walter de Gruyter, Berlin, New York, 1997.
- [6] Young L.C., Generalized curves and the existence of an attained absolute minimum in the calculus of variations, C. R. Soc. Sci. Lett. Varsovie, Classe III, 1937, 30, 212-234.

**MATHEMATICAL THINKING AS AN INDISPENSABLE SKILL TO
SOLVE BOTH EVERYDAY PROBLEMS AND PURELY
MATHEMATICAL ISSUES**

Grażyna Rygał

*Institute of Pre-School and Primary School, Jan Dlugosz University in Czestochowa,
Czestochowa, Poland
g.rygal@ajd.czyst.pl*

Mathematical thinking, logical thinking, and creative thinking are very similar complex skills. Reasoning and mathematical activity for modeling, creating strategies for solving problems and argumentation are of great importance. Mathematical modeling is a reasoning and action that allows us to build a mathematical model corresponding to the situation presented in the task. It is also the right choice of mathematical tools and methods to solve real problems. Creating a problem solving strategy involves correct preparation of an action plan leading from the question to the answer. Arguing is the ability to combine a lot of information and formulate conclusions based on them.

THE CONTROL OF LOCAL AND GLOBAL INSTABILITY REGIONS OF THE SLENDER STRUCTURES

Krzysztof Sokół

*Institute of Mechanics and Machine Design Foundation, Czestochowa University of Technology,
Czestochowa, Poland
sokol@imipkm.pcz.pl,*

Keywords: **local and global instability, slender system, bifurcation**

In the figure 1 the investigated system is presented. The external load is realized by means of the loading heads with circular outline [1]. The system can be composed as two co-axial tubes or tube and rod. The presence of the piezoceramic element divides an internal rod into three sections. The stiffness of connection of those sections is being simulated with rotational springs. The continuity of transversal and longitudinal displacements as well as bending moments and deflection angles is satisfied by natural boundary conditions. Tomski's load is created with the loading head of radius R which can move smoothly in the vertical direction. The radius R has a center in the point localized below the loaded end of the column on its undeformed axis through which passes the line of P force action (pole point). The radius of the receiving head is r and the distance between the end of the column and the contact point of both heads is l_0 .

The phenomenon of local and global instability can be found when nonlinear systems are studied. The instability regions are defined during a comparative analysis on the bifurcation load of a geometrically nonlinear structure to a critical load of a linear one. Taking into account that a slender system keeps a rectilinear form of static equilibrium, one can find such a magnitude of external load at which the instability occurs. The magnitude of this load is called a bifurcation load for nonlinear systems and critical for linear ones. The local instability takes place when the bifurcation load of a nonlinear system is smaller than the critical load of a corresponding linear one. The global instability phenomenon is present when the bifurcation load of a nonlinear system is greater than the critical one of a corresponding linear structure.

The use of the piezoceramic element leads to prestressing of the structure by means of the force generated by this rod after an appliance of the voltage. The prestressing (in relation to the sense of the electric field vector) allows one to achieve a control to the instability type.

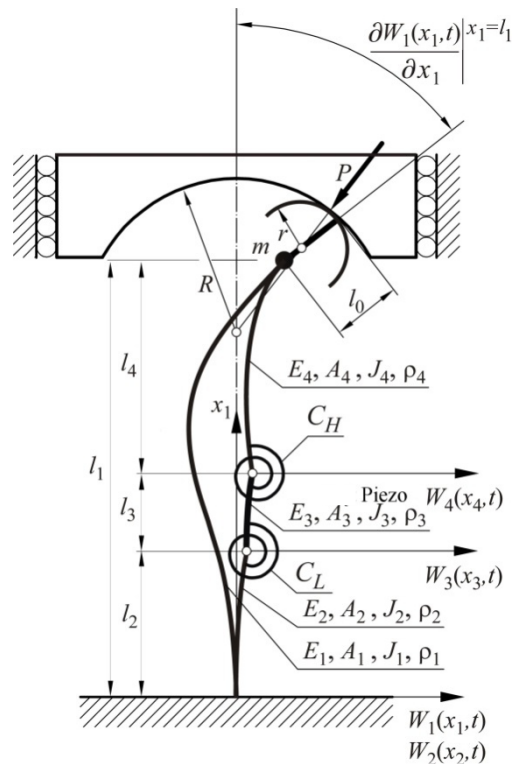

Fig. 1. Investigated system

References

- [1] Tomski L. Uzny S., Vibrations and stability of a column subjected to the specific load realized by circular elements of heads, *Mechanics and Mechanical Engineering*, 2013, 17(2), 197–206.
- [2] Sokół K., The local and global instability and vibration of a nonlinear column subjected to Euler's load, *Scientific Research of the Institute of Mathematics and Computer Science*, 2010, 9(1), 187–194.

REMARKS ABOUT GEOMETRIC SCALE IN ANALYTIC HIERARCHY PROCESS

Tomasz Starczewski

*Institute of Mathematics, Czestochowa University of Technology,
Czestochowa, Poland
tomasz.starczewski@im.pcz.pl*

Keywords: **multicriteria decision analysis, analytic hierarchy process**

The Analytic Hierarchy Process (AHP) is the wide use methodology in multicriteria decision making analysis [1]. The problems of multicriteria decision making often occur in many fields of our activity because real decision problems usually entail any positive and negative consequences in other area. The idea of AHP methodology is to organize multicriteria problem in hierarchy where alternatives are compared in view of one criterion and criteria are compared in view of overriding goal [2]. The order of alternatives in respect to one criterion is made by assigning priority weight to each of them, collected in priority vectors:

$$w = [w_1, w_2, \dots, w_n] \quad (1)$$

Because of some psychological reasons the weights values are obtained by pairwise comparisons each alternative with the others [3],[4].

The pairwise comparison is the main activity of decision maker (DM) in AHP by which a vector of priority weights are obtained. The priority vector is calculated from pairwise comparison matrix which consists of the DM judgments about priority ratios:

$$a_{ij} = \frac{w_i}{w_j} \quad (2)$$

However in AHP practice the DM compare the alternatives or criteria using the common language. This comparisons are converted to numbers which are collected in pairwise comparison matrix [2].

The numbers which are connected to the language expression form set called scale. There are various scales that are used in AHP [5]. The scale invented by AHP author – T. Saaty – consists of nine natural number from 1 to 9 and their reciprocals. That is because there is used nine language expressions for alternative comparison [6]. However some authors argue original idea because of too small amount of possible comparisons or because of its irregular interval between numbers [7],[8],[9],[10].

In response to drawbacks of the original scale the other scales was invented [7],[8],[9]. One of them is geometric scale [8]. In its original form it consists of natural power of number 2 and its reciprocals. The elements of this scale form the

geometric sequence with common ratio 2, so the ratios between its element, in contrast to original AHP scale, is fixed. Because the numbers in this scale are quite big in compare to Saaty scale, the idea of adopting smaller number as a common ratio arises. The geometric scale also can be easy extended to bigger amount of comparisons.

Because of using many forms of geometric scale possibility the question about their actual impact on final results arise. In this paper I would like to present some investigation on this issue. I investigate various common ratio of geometric scale: $(2)^{1/4}$, 1.2, $(1.5)^{1/2}$, $(2)^{1/2}$, 1.5, 1.8, 2 with two different amount of numbers in scale: 17 or 33. The 17 numbers is equal amount of original Saaty comparison numbers, and 33 arise as doubling comparison numbers amount.

In fact, using any scale in AHP procedure entail errors occurrence in final priority vectors. However using any scale is unavoidable so it is important to use scale which lead to possibly small errors. Therefore we investigate the relationship between applying parameters of geometric scale and the amount of errors in priority vector. In this paper I would like to present this results and compare this results with this obtained for genuine Saaty scale. Because an important indicators of pairwise comparison matrices correctness in AHP are inconsistency indices ([2],[3],[11],[12],[13]) I also present impact geometric scales with various parameters on matrix inconsistency and on correlation between inconsistency indices and errors in priority vectors.

My investigation was based on Monte Carlo experiments. The framework of this simulation is similar to existing in literature simulation [13],[14]. In this experiments the “true” priority vector and “true” pairwise comparison matrix are generated. In the next step of experiment the pairwise comparison matrix is disturbing by a random factor in order to simulate the “real” situation, when the DM make mistakes in their matrix. Next the numbers in matrix are rounded to the nearest numbers from used scale and the priority vector is calculated from the matrix. Obtained vector is compared with initially generated vector and the errors are calculated. For obtained matrices the inconsistency indices values are calculated and are compared with errors in priority vectors.

The figures below present histograms created upon results that are obtained for various scale parameters.

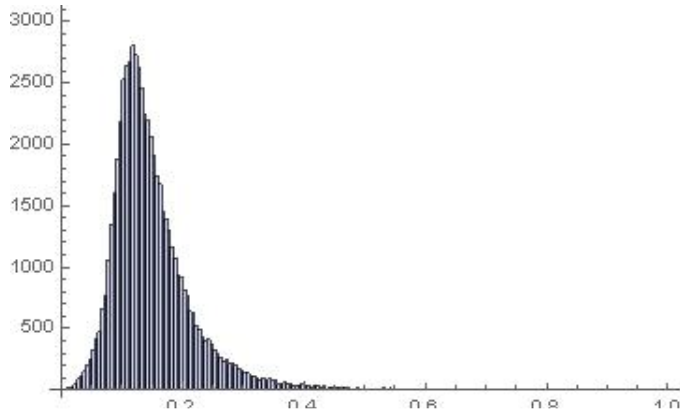

Fig. 1. RE in PV for geometric scale with common ratio $2^{1/4}$, and 33 numbers

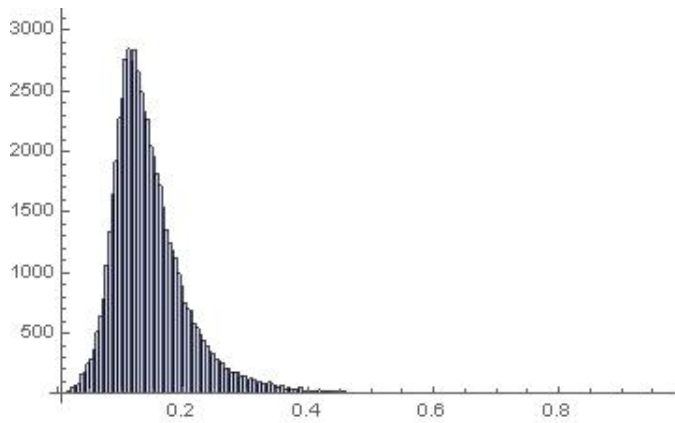

Fig. 2. RE in PV for geometric scale with common ratio 1.2, and 17 numbers

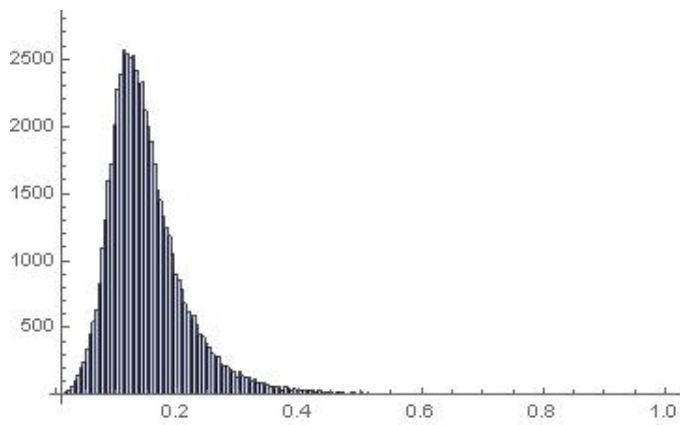

Fig. 3. RE in PV for geometric scale with common ratio $2^{1/2}$, and 17 numbers

Above figures present histograms of relative errors in priority vectors obtained from matrices 5x5 with geometric method. Matrices are disturbing by random factor with standard deviation equal 0.1, 0.2 and 0.3. One random chosen element of matrix is multiple by 3. The results obtained for various parameters and amount of elements are similar what is quite surprising.

References

- [1] Vaidya O.S., Kumar S. Analytic hierarchy process: An overview of applications, *European Journal of Operational Research*. 2006, 169, 1–29.
- [2] Saaty T.L., *The analytic hierarchy process*. New York: McGrawHill, 1980.
- [3] Saaty T.L., Scaling method for priorities in hierarchical structures, *Journal of Mathematical Psychology*. 1977, 15(3), 234–281.
- [4] Ishizaka, A., Labib, A., Review of the main developments in the analytic hierarchy process, *Expert Systems with Applications*. 2011, 38(11), 14336–14345.
- [5] Franek J., Kresta A., Judgment scales and consistency measure in AHP, *Procedia Economics and Finance*. 2014, 12, 164 – 173.
- [6] Saaty T.L., Decision Making – The Analytic Hierarchy and Network Processes (AHP/ANP), *Journal of Systems Science and Systems Engineering*. 2004, 13(1), 1-35.
- [7] Harker P., Vargas L., The Theory of Ratio Scale Estimation: Saaty's Analytic Hierarchy Process. *Management Science*. 1987, 33(11), 1383–1403.
- [8] Lootsma F., Conflict Resolution via Pairwise Comparison of Concessions. *European Journal of Operational Research*. Elsevier: Amsterdam. 1989, 40(1), 109–116.
- [9] Salo A., Hamalainen R., On the Measurement of Preference in the Analytic Hierarchy Process, *Journal of Multi-Criteria Decision Analysis*. 1997, 6(6), 309–319.
- [10] Dong Y. et al., A comparative study of the numerical scales and the prioritization methods in AHP, *European Journal of Operational Research*. 2008, 186, 229–242.
- [11] Koczkodaj W. W., A new definition of consistency of pairwise comparisons. *Mathematical and Computer Modelling*. 1993, 18(7), 79–84.
- [12] Lamata M., Peláez P., A method for improving the consistency of judgements, *International Journal of Uncertainty, Fuzziness and Knowledge-Based Systems*. 2002 10(6), 677–686.
- [13] Grzybowski A.Z., New results on inconsistency indices and their relationship with the quality of priority vector estimation, *Expert Systems With Applications*. 2016, 43, 197–212.
- [14] Grzybowski A. Z, Note on a new optimization based approach for estimating priority weights and related consistency index. *Expert Systems with Applications*. 2012 39, 11699–11708.

NEW LEARNING TOOLS FOR TEACHING THE SEMANTICS OF PROGRAMMING LANGUAGES

William Steingartner¹, Valerie Novitzká²

^{1,2}*Faculty of Electrical Engineering and Informatics, Technical University of Košice,
Košice, Slovakia*

¹*william.steingartner@tuke.sk, ²valerie.novitzka@tuke.sk,*

Abstract. Formal methods in software engineering play an essential *rôle* in software development process. In recent years, we have prepared software package consisting of more modules, where each of them handles some semantic method. In this paper we present two new modules added to our software package – a module for handling the mathematical expressions and a module for visualizing the categorical denotational semantics.

Keywords: **compiler, formal methods, semantics of programming languages, teaching software, visualization**

1. Introduction

Nowadays, software engineering education must to teach many new skills. In fact, software engineering does not mean only to write better programs [1, 2]. Formal methods are very important for developing of correct software systems, in particular to verify the correctness of the systems or at least of some desired aspects of their behavior. Still new technologies are used in practical approach and many of them are coming from formal methods. To help future software experts with understanding of formal methods grounded in semantics, learning software that illustrates and visualizes important techniques seems to be very fruitful [3].

In this paper we present two new modules integrated to our software package – a module which handles the mathematical expressions (analysis, evaluation, abstract syntax tree, postfix form) and a module which visualizes the denotation of a program in categorical morphisms. In the second section our software package is briefly introduced. A tool handling the mathematical expressions is described in the third section and a tool for visualization of a running program in the fourth section.

2. Our Software Package

Teaching of the course on Semantics of programming languages is supported by our software package consisting of several modules. Actually, the software package contains the following modules:

- a compiler from source code written in the Jane language into code of an abstract machine, which is a source-to-source compiler;
- an emulator of an abstract machine code – a module, which executes the instructions of an abstract machine and shows an actual memory state and an evaluation stack;
- a decompiler of an abstract machine code back into source written in the Jane language, which is also a source-to-source compiler;
- a tool for visualization of program execution based on categorical denotational semantics defined in [4]; and
- a tool for handling the arithmetic and Boolean expressions.

The last two listed modules are new and they actually extended the previously built software package presented in [5]. A general scheme of the new extended software package is in Fig. 1.

The main motivation for this integrated software package was to help students to understand better formal semantics, and to motivate them to make their own experiments. We follow the joint research goal based on common research work [6].

3. Tool for Arithmetic Expressions

Arithmetic and Boolean expressions are very widely used in programming. During the lot of programs executions some expressions are evaluated and possibly stored in the memory. They can stand on a right-hand side of an assignment statement

$$x := e$$

or their values are used in the conditional and loop statements. In those cases, the values are never stored and they are used as transients.

Because the work with expressions is considered as fundamental, we decided to prepare the software which allows to this process easier. A tool for handling the arithmetic expressions allows to use the following functions: the program

- checks the input expression and to recognize the type (arithmetic or Boolean one);
- realizes the error recovery;
- allows a user to input the values for particular variables identified in the expression entered;

- evaluates an expression with input values (can be possibly changed interactively, in any time);
- produces the post fix form of an expression;
- draws the abstract syntax tree for an input expression in three versions (only variable names, only values or variable names with values, resp.); and
- stores the graphic output into file for later use.

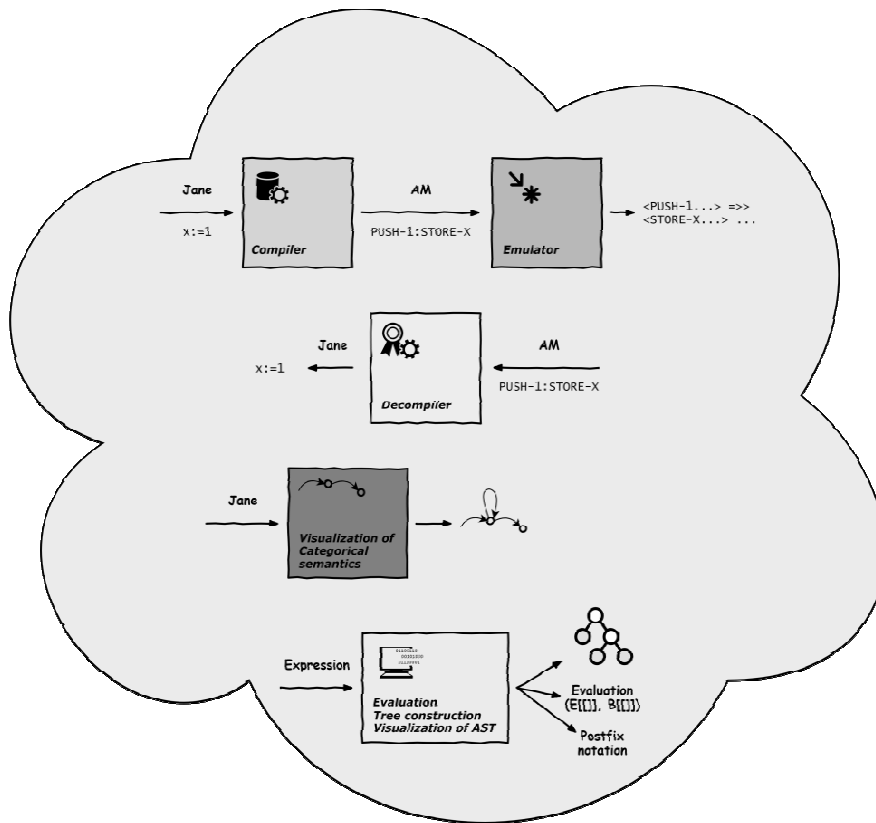

Fig. 1 A general scheme of teaching software package for course on Semantics

The module uses for checking the expressions the basic inference rules for arithmetic and Boolean expressions

$$e ::= n|x|e + e|e - e|e * e|(e),$$

$$b ::= false|true|\neg b|b \wedge b|e \leq e|e = e|(b),$$

and extended rules with some extra operations

$$\begin{aligned}
 e &::= n|x|e + e|e - e|e * e|e/e| - e| + e|(e), \\
 b &::= false|true| \neg b| b \wedge b |b \vee b|e \leq e|e = e|(b).
 \end{aligned}$$

A user can input the values of expressions and possibly change them interactively, in any time. An expression can be evaluated immediately when a user entered the values for all found variables. After changing the values, an expression can be recalculated. The resulting values of particular expressions are calculated with the semantic functions for arithmetic and Boolean expressions defined e.g. in [7] or in [8] using the standard mathematical rules with preserving the associativity and precedence of operators. If an error in checking the expression occurs, an error-recovery procedure is applied with information about the errors with possible positions in an input expressions. Furthermore, the program converts the input expressions in infix form into the postfix form, the program produces graphic output with an abstract syntax tree of an input expression.

The application is now successfully used as a learning tool for the students of the course Semantics of programming languages:

- for preparing the lecture materials and laboratory exercises;
- for individual study and the for the experimental approach to learning; and
- for preparing the testing and exam materials.

4. Visualizing Tool for Categorical Denotational Semantics

A module, which handles the source code written in Jane and shows how the program is being executed with denotational semantics in categorical structures, is also a new module in our software package. This module takes as input a text consisting of well-structured statements of the language Jane according the following inference rule:

$$S ::= x := e|skip|S; S|if b then S else S|while b do S.$$

An output of this program is a path in category consisting of morphisms that represent each step of execution. Categorical approach to denotational semantics is defined in [4] and the program follows those definitions of categorical representations of a program constructs. Visual expressing of the meaning of programs in categories is illustrative and demonstrative. Graphical output can help better understand particular steps of execution inside the program within the changes of variables stored in memory. A module simply reads source text from a file or allows user to write the source directly. The next step is to setting up the values of program variables. Starting of simulation consists of several steps. The lexical and syntax analysis – the traditional phases of compiler are executed: white characters are dropped and input is checked. If an error occurs, a program shows an information about it and it stops the translation of input source text. A semantic analysis is very simple, because a language Jane uses only two implicit types –

integers for arithmetic expressions and two-values Boolean type for Boolean expressions.

We show as an example how the input program is processed. We take the following program as a source code for a program. It takes input values: x as a dividend and y as divisor. The program calculates an integer quotient (stored in z) and a remainder (stored in x).

```

begin
  z := 0;
  while (y ≤ x)do (
    z := z + 1;
    x := x - y;)
end;
    
```

Categorical denotational semantics of this program is a compound morphisms and its graphical representation is in Fig. 2.

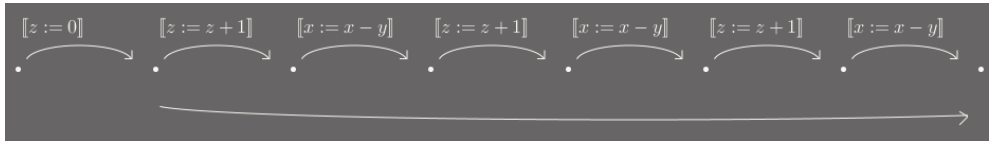

Fig. 2 Categorical denotational semantics of a given program

After setting the starting values x with 17 and y with 5, the program calculates all states which arise during the run of a program. State table is depicted in Fig. 3.

States	Variables	Values
State 0	x	17
State 0	y	5
State 0	z	0
State 1	z	0
State 2	z	1
State 3	x	12
State 4	z	2
State 5	x	7
State 6	z	3
State 7	x	2

Fig. 3 A state table during the running of a program

5. Conclusion

We have presented in this paper the new parts integrated into our learning software. These modules provide graphic outputs which are very easy to understand and they can help in learning and in teaching process for the course Semantics of programming languages. We want to extend our learning software package with other modules based on operational semantics with categorical structures and coalgebras according to [9] and for the other important and relevant semantic methods.

Acknowledgment

This work has been supported by the Slovak Research and Development Agency under the contract No. SK-AT-2017-0012: Semantics technologies for computer science education.

References

- [1] Wordsworth J., Education in formal methods for software engineering, Information and Software Technology, 1987, Vol., 29, No. 1, pp. 27-32.
- [2] Batra M., Malik A., Dave M., Formal methods: benefits, challenges and future direction, Journal of Global Research in Computer Science, 2013, Vol. 4, No. 5, pp. 21-25.
- [3] Steingartner W., Eldojali M., Radaković D., Dostál J., Software support for course in semantics of programming languages, In: 2017 IEEE 14th International Scientific Conference on Informatics, Poprad, Slovakia, Nov 14-16 2017, pp. 359-364, Danvers, USA.
- [4] Steingartner W., Novitzká V., Bačíková M., Korečko Š., New Approach to Categorical Semantics for Procedural Languages, Computing and Informatics, Bratislava, 2017, Vol. 36, No. 6, pp. 1385-1414.
- [5] Steingartner W., Novitzká V., Learning tools in course on Semantics of programming languages, In: 9th Conference on Mathematical Modeling in Physics and Engineering, pp. 137-142, Technical University of Czestochowa, Poland.
- [6] Schreiner W., Steingartner W., Visualizing Execution Traces in RISCAL, Technical Report, Research Institute for Symbolic Computations (RISC), Johannes Kepler University, Linz, Austria, March 2018.
- [7] Nielson H.R., Nielson F., Semantics with application: An appetizer, Springer-Verlag London, 2007.
- [8] Steingartner W., Novitzká V., Semantics of programming languages, Technical University of Košice, Slovakia, 2015 (in Slovak).
- [9] Steingartner W., Novitzká V., Eldojali M., Radaković D., Some aspects about coalgebras as foundations for expressing the semantics of imperative languages, Mathematics and Computer Science – MaCS 2016, Proceedings of the 11th Joint Conference on Mathematics and Computer Science, Eger, Hungary, May 20-22 2016, CEUR-WS.org, online ceur-ws.org/Vol-2046/

THE INFLUENCE OF MOUNTING RIGIDITY ON STABILITY AND STRENGTH OF CYLINDER BARRELS OF A TELESCOPIC HYDRAULIC CYLINDER

Sebastian Uzny¹, Łukasz Kutrowski²

^{1,2}Institute of Mechanics and Machine Design Fundamentals, Czestochowa University of Technology, Czestochowa, Poland

¹uzny@imipkm.pcz.pl, ²kutrowski@imipkm.pcz.pl

Keywords: stability, hydraulic telescopic cylinder, slender system, Lamé's theory

In construction equipment, in particular, various types of excavators, hydraulic cylinder are used. They are responsible for the movement of individual machine parts. The length of the piston rod limits the working range of the cylinders, which in the case of construction machine members is relatively small. In the case when a wide operating range is required, telescopic hydraulic cylinders are used, which are characterized by a larger number of components. Multistage cylinders consist of a piston rod and several cylinders. They are used in lifting systems in semi-trailers of trucks, elevators with hydraulic drive or as mining supports, so-called hydraulic stands.

Due to the considerable length of these systems in combination with a relatively small cross-section they can be treated as slender systems. Therefore, when analyzing the strength of hydraulic cylinders, the strength of the material and buckling criterion should be taken into account. Pinned mounting on both sides is a typical way of mounting hydraulic cylinders. The wear of the actuator eyes in connection with possible soiling and corrosion may result in the occurrence of additional friction forces, occurring in the actuator connections with the lifting system in the truck.

Stability analysis of hydraulic cylinders was presented in papers [1-4]. In this work, the effect of the mounting rigidity of the telescopic hydraulic cylinder on its strength and stability was analyzed. The boundary value problem regarding to the stability of the system was carried out on the basis of the static stability criterion. To determine the maximum load capacity from the point of view of material effort, the Lamé theory for thick-walled tubes was used.

The first picture shows a diagram of a telescopic hydraulic cylinder, taking into account Euler's load. This system consists of $n-1$ cylinders and piston rod. The hydraulic telescopic cylinder is considered as a fully extended system due to the fact that in this case it has the least stiffness. Rotational springs C_R modelling the rigidity of the guiding and sealing elements were introduced between following members. Two rotational springs C_{R0} and C_{Rn} are analyzed in the mounting locations, which model the occurrence of additional resistances in the joint connection.

Diameter of the cylinders (outer d_{zi} and inner d_{wi}) were defined as:

$$d_{zi} = d_t + 2(n-i)g_U + 2(n-i)g_R ; d_{wi} = d_t + 2(n-i)g_U + 2(n-i-1)g_R \quad (1a,b)$$

where: g_U - thickness of sealing element; g_R thickness of cylinder.

Each element of the hydraulic cylinder is characterized by adequate flexural rigidity $(EJ)_i$. Elements of the structure marked as $i = 1, 2, \dots, n-1$ correspond to cylinders and the n -element correspond to piston rod.

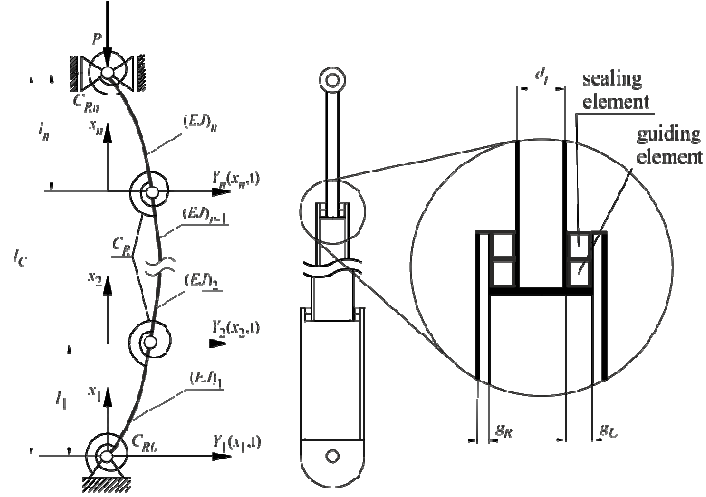

Fig. 1. Scheme of n-stage telescopic hydraulic cylinder subjected to Euler's load

Potential energy of the system can be written as:

$$\begin{aligned} V = & \frac{1}{2} \sum_{i=1}^n \int_0^{l_i} (EJ)_i \left(\frac{d^2 w_i(x_i)}{dx_i^2} \right)^2 dx_i - \frac{1}{2} P \sum_{i=1}^n \int_0^{l_i} \left(\frac{dw_i(x_i)}{dx_i} \right)^2 dx_i + \frac{1}{2} C_{R0} \left(\frac{dw_1(x_1)}{dx_1} \Big|_{x_1=0} \right)^2 + \\ & + \frac{1}{2} C_{Rn} \left(\frac{dw_n(x_n)}{dx_n} \Big|_{x_n=l_n} \right)^2 + \frac{1}{2} C_R \sum_{i=1}^n \int_0^{l_i} \left[\frac{dw_i(x_i)}{dx_i} \Big|_{x_i=l_i} - \frac{dw_{i+1}(x_{i+1})}{dx_{i+1}} \Big|_{x_{i+1}=0} \right]^2 dx_i \end{aligned} \quad (2)$$

Taking into account the potential energy in the principle of minimum potential energy ($\delta V=0$), after appropriate mathematical transformations, equations of displacement (3) and natural boundary conditions of the system (4a-h) are obtained in form:

$$(EI)_i \frac{d^4 w_i(x_i)}{dx_i^4} + P \frac{d^2 w_i(x_i)}{dx_i^2} = 0 \quad (3)$$

$$\begin{aligned} & -(EI)_1 \frac{d^2 w_1(x_1)}{dx_1^2} \Big|_{x=0} + C_{R0} \frac{dw_1(x_1)}{dx_1} \Big|_{x=0} = 0 ; (EI)_n \frac{d^2 w_n(x_n)}{dx_n^2} \Big|_{x_n=l_n} + C_{Rn} \frac{dw_n(x_n)}{dx_n} \Big|_{x_n=l_n} = 0 \\ & w_i(l_i) = w_{i+1}(0) ; - (EI)_{i+1} \frac{d^2 w_{i+1}(x_{i+1})}{dx_{i+1}^2} \Big|_{x_{i+1}=0} - C_R \left[\frac{dw_i(x_i)}{dx_i} \Big|_{x_i=l_i} - \frac{dw_{i+1}(x_{i+1})}{dx_{i+1}} \Big|_{x_{i+1}=0} \right] = 0 \\ & - (EI)_i \frac{d^3 w_i(x_i)}{dx_i^3} \Big|_{x_i=l_i} + (EI)_{i+1} \frac{d^3 w_{i+1}(x_{i+1})}{dx_{i+1}^3} \Big|_{x_{i+1}=0} - P \frac{dw_i(x_i)}{dx_i} \Big|_{x_i=l_i} + P \frac{dw_{i+1}(x_{i+1})}{dx_{i+1}} \Big|_{x_{i+1}=0} = 0 \\ & w_1(0) = 0 ; w_n(l_n) = 0 ; (EI)_i \frac{d^2 w_i(x_i)}{dx_i^2} \Big|_{x_i=l_i} + C_R \left[\frac{dw_i(x_i)}{dx_i} \Big|_{x_i=l_i} - \frac{dw_{i+1}(x_{i+1})}{dx_{i+1}} \Big|_{x_{i+1}=0} \right] = 0 \end{aligned}$$

(4a-h)

Solution of equations of displacement can be written as follow:

$$w_i(x_i) = A_i \sin(k_i x_i) + B_i \cos(k_i x_i) + C_i x_i + D_i ; k_i^2 = \frac{P}{(EI)_i} \quad (5a,b)$$

Taking into account the solution (5) in boundary conditions, system of equations is obtained. Determinant of the coefficients matrix of this system equated to zero is an equation, from which the critical load of the system can be calculated.

Results of the numerical calculations, which include the influence of mounting rigidity on stability and strength of cylinder barrel, are presented using non-dimensional parameters:

$$\zeta_{GU} = \frac{g_U}{d_i} ; \zeta_{GR} = \frac{g_R}{d_i} ; \zeta_{CR} = \frac{C_R l_C}{(EI)_n} ; \zeta_{CR0} = \frac{C_{R0} l_C}{(EI)_n} ; \zeta_{CRn} = \frac{C_{Rn} l_C}{(EI)_n} ; \lambda_{cr} = \frac{P_{cr} l_C^2}{(EI)_n} \quad (6a-f)$$

In the Fig.2 dependence between the critical load parameter λ_{cr} and the stiffness parameters of rotational springs in the mounting locations of the hydraulic cylinder ζ_{CR0} and ζ_{CRn} for three configurations is presented. The curve number 1 refers to the change in the parameter ζ_{CRn} (spring in the top mounting). The curve number 2 refers to the change in the parameter ζ_{CR0} (spring in the bottom mounting). In contrast, curve number 3 refers to the simultaneous change of both stiffness parameters, which is assumed to be equal. Horizontal curves relate to the critical load at the predetermined maximum allowable stress equal to the limit of elasticity. The index at the symbol λ expresses the value of the accepted stresses in MPa.

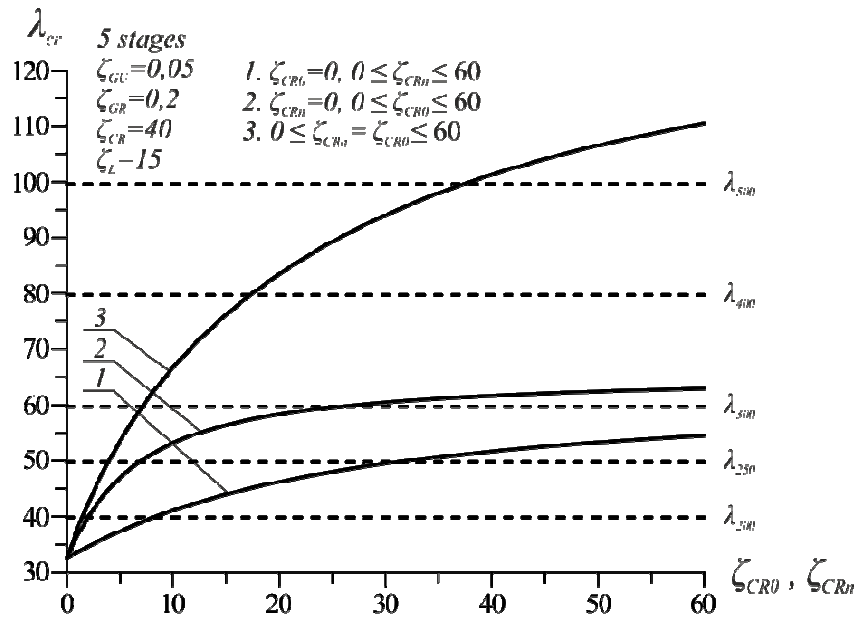

Fig. 2. The influence of stiffness parameter ζ_{CRO} and ζ_{CRn} on stability and strength of cylinder barrel

On the basis of obtained results, it is stated that a greater impact on the critical load value has an elastic mounting at the end of the cylinder barrel mounting (bottom end) in comparison to the point of piston rod mounting. The use of an elastic fastening at both ends results in a much greater increase in the critical load of the hydraulic cylinder compared to the use of an elastic mounting only at one of its ends. The intersections of the buckling curves with stress lines shown in Fig. 2 define the areas of the system destruction as a result of loss of stability and material effort for different values of allowable stresses.

References

- [1] Tomski L., Elastic Carrying Capacity of a Hydraulic Prop, Engineering Transactions 1977, 25(2), pp. 247-263.
- [2] Tomski L.: Elastic Stability of Hydraulic Props of Longwall Supports, Archives of Mining Science, 1978, 23(3), pp. 217-231.
- [3] Tomski L., Uzny S.: Stateczność i drgania swobodne siłownika hydraulicznego sprężyste zamocowanego, Zeszyty Naukowe Politechniki Rzeszowskiej. seria: Mechanika, 2008, 258, 74, pp. 369-380.
- [4] Uzny S., Sokół K., Kutrowski Ł., Stability of a Hydraulic Telescopic Cylinder Subjected to Euler's Load, In: Rusiński E., Pietrusiak D. (eds), Proceedings of the 13th International Scientific Conference. RESRB 2016. Lecture Notes in Mechanical Engineering, Springer, 2017

NONLINEAR COMPONENT OF FREE VIBRATION FREQUENCY OF PARTIALLY TENSIONED SYSTEM WITH CONSIDERATION OF ROTATIONAL STIFFNESS OF SUPPORT

Sebastian Uzny¹, Michał Osadnik²

^{1,2} *Institute of Mechanics and Machine Design Fundamentals, Czestochowa University of Technology
Czestochowa, Poland*

¹ *uzny@imipkm.pcz.pl, ² m.osadnik@imipkm.pcz.pl*

Keywords: slender nonlinear systems, amplitude of vibrations, Euler's load

Geometrically non-linear systems (columns, beams) are the object of many studies [1,2,3,4] in which the nonlinear theory and the theory of Bernoulli – Euler are used to formulate the boundary problem. One of interesting non-linear structures is the partially tensioned column, which was presented in the works [5,6,7,8]. The publications show the crucial influence of discrete elements on the vibrations frequency [3,7] and stability [6] (the natural vibrations frequency and critical force of the system can be controlled).

In this paper the influence of parameters such as translational and rotational stiffness of used springs and external load magnitude for variable location on vibration frequency (nonlinear component) is presented. The column in question corresponds to a screw drive system, which is used in platform lifts (equipped with an engine room located in the lower part of the frame).

An external force is applied between the elements of the slender structure showed in the figure 1. The Euler's load subjected in point O does not change the line of action during the system deflection. The point of force application (described with parameter ζ) can be changed along the entire length of the rod as it happens when the screw-drive lift platform transport different load on various lifting height. In order to form a mathematical model the overall length of the system is divided into two parts respectively of lengths l_1 and l_2 (compressed lower part is indicated by the index 1 and tensioned upper part by the index 2). The considered structure is characterized (in whole length) by constant bending stiffness $((EJ)_1 = (EJ)_2 = (EJ))$, compression stiffness $((EA)_1 = (EA)_2 = (EA))$ and mass $((\rho A)_1 = (\rho A)_2 = (\rho A))$ (where: E_i – Young's modulus, ρ_i – density, A_i – cross section area, J_i – geometrical axial moment of inertia of cross section of i -th element of the structure). The longitudinal displacement and rotation on the both of system ends are limited by the discrete elements in a form of translational (K_0, K_1) and rotational (C_0, C_1) springs.

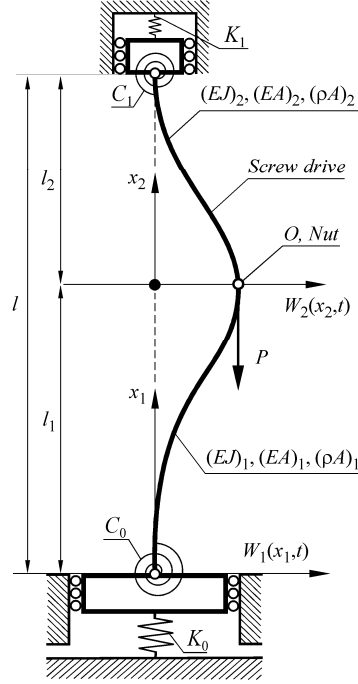

Fig. 1. Physical model of considered column

Differential equations of motion and natural boundary conditions of considered structure has been formulated on the basis of Hamilton's principle and Bernoulli – Euler theory. The differential equations of motion in transversal and longitudinal directions of the system are as follows:

$$\frac{\partial^4 w_i(\xi_i, \tau)}{\partial \xi_i^4} + k_i^2(\tau) \frac{\partial^2 w_i(\xi_i, \tau)}{\partial \xi_i^2} + \Omega_i^2 \frac{\partial^2 w_i(\xi_i, \tau)}{\partial \tau^2} = 0 \quad (1)$$

$$u_i(\xi_i, \tau) - u_i(0, \tau) = -\frac{k_i^2(\tau)}{\theta_i} \xi_i - \frac{1}{2} \int_0^{\xi_i} \left(\frac{\partial w_i(\xi_i, \tau)}{\partial \xi_i} \right)^2 d\xi_i \quad (2)$$

Equations (1) and (2) are written in the non-dimensional form using the following relations:

$$\xi_i = \frac{x_i}{l_i}, \quad w_i(\xi_i, \tau) = \frac{W_i(x_i, \tau)}{l_i}, \quad u_i(\xi_i, \tau) = \frac{U_i(x_i, \tau)}{l_i}, \quad k_i^2(\tau) = \frac{S_i(\tau) l_i^2}{(EJ)_i},$$

$$\Omega_i^2 = \frac{(\rho A)_i \omega^2 l_i^4}{(EJ)_i}, \quad \tau = \omega t, \quad \Theta_i = \frac{A_i l_i^2}{J_i}, \quad i = 1, 2 \quad (3a-h)$$

Where: $S_i(\tau)$ – internal force in i -th element of the structure, ω - vibration frequency, $W_i(x_i, \tau)$, $U_i(x_i, \tau)$ – transversal and longitudinal displacements.

The geometrical and natural boundary conditions are presented below:

$$\begin{aligned}
 w_1(1, \tau)l_1 &= w_2(0, \tau)l_2; \quad w_1'(\xi_1, \tau)\Big|_{\xi_1=1} = w_2'(\xi_2, \tau)\Big|_{\xi_2=0}; \quad u_1(1, \tau)l_1 = u_2(0, \tau)l_2; \\
 w_1(0, \tau) &= w_2(1, \tau) = 0; \\
 (EJ)_1 w_1''(\xi_1, \tau)\frac{1}{l_1} - C_0 w_1'(\xi_1, \tau)\Big|_{\xi_1=0} &= 0; \quad k_1^2(\tau)\frac{(EJ)_2}{l_1^2} - K_0 u_1(1, \tau)l_1 = 0; \\
 -(EJ)_2 w_2''(\xi_2, \tau)\frac{1}{l_2} - C_1 w_2'(\xi_2, \tau)\Big|_{\xi_2=1} &= 0; \quad k_2^2(\tau)\frac{(EJ)_2}{l_2^2} - K_1 u_2(1, \tau)l_2 = 0; \\
 (EJ)_1 l_2 w_1''(\xi_1, \tau)\Big|_{\xi_1=1} - (EJ)_2 l_1 w_2''(\xi_2, \tau)\Big|_{\xi_2=0} &= 0; \\
 (EJ)_1 l_2^2 w_1'''(\xi_1, \tau)\Big|_{\xi_1=1} - (EJ)_2 l_1^2 w_2'''(\xi_2, \tau)\Big|_{\xi_2=0} + Pl_2^2 l_1^2 w_2'(\xi_2, \tau)\Big|_{\xi_2=0} &= 0; \\
 k_1^2(\tau)\frac{(EJ)_1}{l_1^2} - k_2^2(\tau)\frac{(EJ)_2}{l_2^2} - P &= 0 \tag{4a-k}
 \end{aligned}$$

Results of numerical simulations of free vibrations (including linear ω_0 and nonlinear ω_2 components of free vibrations frequency) of the considered partially tensioned slender system were presented in the non-dimensional form, defined as:

$$\lambda = \frac{Pl^2}{(EJ)_1}, \quad c_j = \frac{C_j l}{(EJ)_1}, \quad k_j = \frac{K_j l^3}{(EJ)_1}, \quad \zeta = \frac{l_1}{l}, \quad \Omega_2 = \frac{\omega_2^2(\rho A)_1 l^4}{(EJ)_1}, \quad j = 1, 2 \tag{5a-f}$$

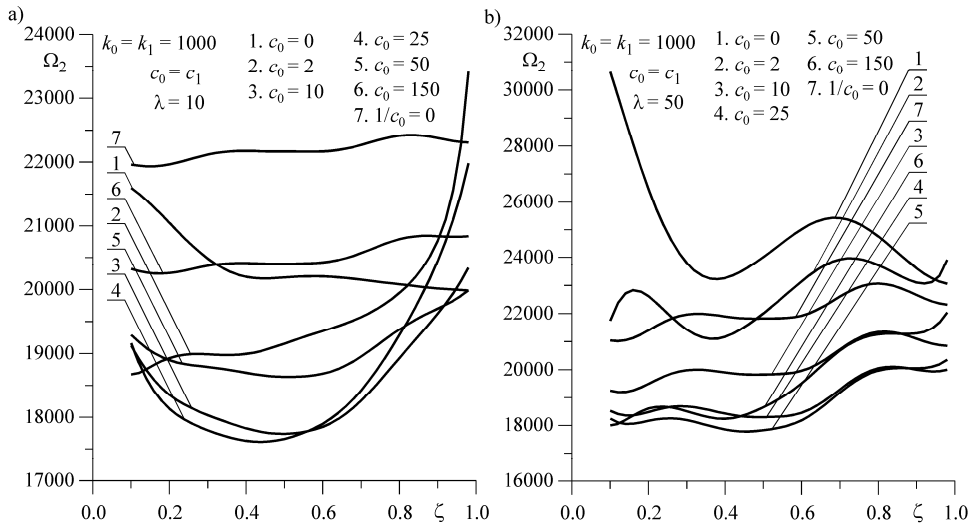

Fig. 2a-b. The relationship between nonlinear component of the free vibration frequency Ω_2 and external load application point ζ at different rotational springs stiffness.

In the figure 2 the relationship between nonlinear component of vibration frequency and the ζ parameter (which shows the location of Euler's load application) in combination for different rotational springs stiffness is plotted. In simulations it has been assumed that external load magnitude $\lambda = 10$ (figure 2a) and $\lambda = 50$ (figure 2b), translational stiffness is $k_0 = k_1 = 1000$ and rotational stiffness $c_0 = c_1$. An influence of the rotational springs stiffness on dynamic behavior were analyzed. On the basis of the obtained results, it can be concluded that the rotational stiffness has great influence on the magnitude of non-linear component vibration frequency. The linear and non-linear component of vibration frequency changes in relation to the location of the external force ζ at given rotational stiffness. For higher magnitude of the external load, the greater difference in vibration frequency was obtained.

Acknowledgement

The study has been carried out within the statutory funds of the Czestochowa University of Technology BS/PB 1-101/3020/17/P and BS/MN 1-101/306/17/P.

References

- [1] L.Y. Jiang, Z. Yan, Timoshenko beam model for static bending of nanowires with surface effects, *Physica E* 42, 2010, 2274-2279.
- [2] Awrejcewicz J., Saltykova O.A., Chebotyrevskiy Yu.B., Krysko V.A., Nonlinear vibrations of the Euler-Bernoulli beam subjected to transversal load and impact actions, *Nonlinear Studies*, 18(3), 2011, 329-364.
- [3] Sundararajan C., Influence of an elastic end support on the vibration and stability of Beck's column, *Int. J. Mech. Sci.* 18, 1976, 239-241.
- [4] J. Przybylski, L. Tomski, *Vibration of an Initially Prestressed Compound Column under Axial Compression*, Elsevier Science Publishers B.V., 1992, 263-268.
- [5] Uzny S., Sokół K., Osadnik M., Free vibrations of the partially tensioned geometrically non-linear system subjected to Euler's load, *Vibrations in Physical Systems* 27, 2016, 399-406.
- [6] Uzny S., Osadnik M., Influence of longitudinal elastic support on stability of a partially tensioned column, *Book Series: Engineering Mechanics*, 2017, 1006- 1009.
- [7] Uzny S., Osadnik M., Influence of the longitudinal spring element on free vibrations of the partially tensioned column, *Procedia Engineering*, 17, 2017, 135-140.
- [8] Uzny S., Sokół K., Osadnik M., Influence of amplitude on free vibration frequency of a partially tensioned column, *Book Series: Engineering Mechanics*, 2016, 562-565.

THE DETERMINATION OF STRESS-STRAIN RELATIONS FOR STEELS CONSIDERING THE INFLUENCE OF TEMPERATURE

Jerzy Winczek

*Institute of Mechanical Technologies, Czestochowa University of Technology,
Czestochowa, Poland
winczek@imipkm.pcz.czest.pl*

Keywords: **modeling, thermomechanics, tensile curve**

In the thermomechanical state calculation in the technological processes of metals and their alloys, the mechanical properties of the material depending on temperature are used, including tensile (compression) curves. These properties are determined based on the results of a static tensile test performed at different temperatures. In this area, intensive research of mechanical properties of steel are carried out [1 - 3], also due to their fire resistance [4].

Stress-strain dependencies can be defined in the form of curve points (Fig. 1) [3, 5].

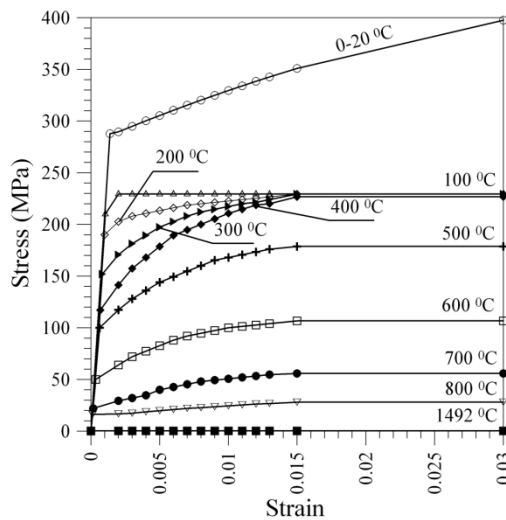

Fig. 1. Tensile curves depending on the temperature for S235 steel [5].

Often, other parameters of the tensile curve as a function of temperature are used, such as the longitudinal modulus (Young modulus) E , strain hardening modulus, yield stress σ_0 and tensile strength TS . In the elastic range ($\sigma < \sigma_0$), the stress-strain function is described in accordance with Hooke's law:

$$\sigma(\varepsilon, T) = E(T)\varepsilon \quad (1)$$

where: σ – stress value of tension curve, ε - strain, T – temperature, σ_0 – yield stress, E – Young modulus,

In the elastic-plastic range, the tensile curve is described by a function or by a strain hardening modulus. The strain hardening functions were the subject of researchers' interest in the first half of the 20th century. Ludwik [6] began a modelling of the stress-strain curve and described it with following function:

$$\sigma = \sigma_0 + K_L \varepsilon^{n_L} \quad (2)$$

where σ represents stress, σ_0 yield stress, ε plastic strain, K_L and n_L are the experimentally determined parameters. In turn, Hollomon [7, 8] suggested a function:

$$\sigma = K_H \varepsilon^{n_H} \quad (3)$$

Swift [9] regarding the Hollomon's law introduced the constant into the strain term:

$$\varepsilon = \varepsilon_0 + K_S \sigma^{n_S} \text{ or } \sigma = K'_S (\varepsilon + \varepsilon_0)^{n'_S} \quad (4)$$

where ε_0 , K_S , K'_S , n_S i n'_S are the parameters.

Generating the function tensile curves can be described in the form:

$$\sigma(\varepsilon, T) = \sigma_o(T) + \sigma_{sh}(\varepsilon - \varepsilon_0, T) \quad (5)$$

where: σ_o – limit of elasticity or yield stress, σ_{sh} - strain hardening function, ε_0 – the strain corresponding to yield stress σ_o determined by the dependence:

$$\varepsilon_0(T) = \frac{\sigma_o(T)}{E(T)} \quad (6)$$

When using the strain hardening modulus, which is the tangent of the angle of inclination of the function to the axis ε (Fig. 2a) this module is defined as follows:

$$\sigma_{sh}(T) = \frac{TS(T) - \sigma_o(T)}{\varepsilon_{max}(T) - \varepsilon_0(T)} \quad (7)$$

In the case of elastic - ideal plastic material $\sigma_{sh}(T) = 0$ the tensile curve is straight parallel to the axis ε (Fig. 2b).

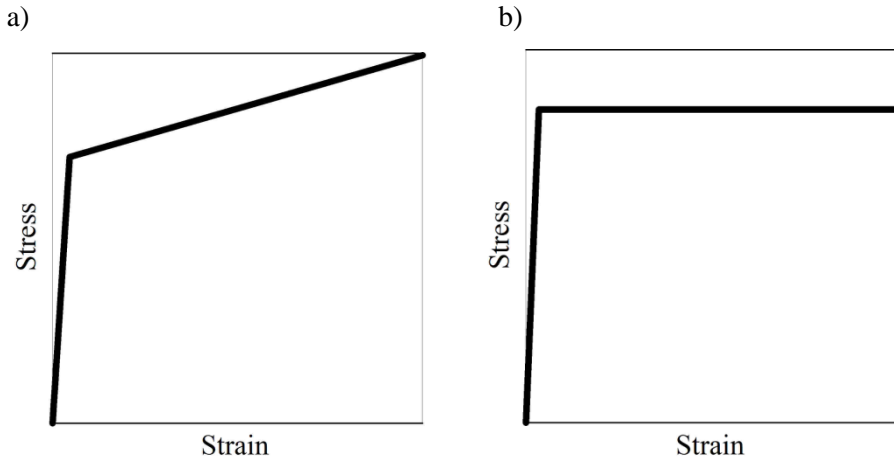

Fig. 2. Stress-strain curves: a) with strengthening; b) without strengthening.

The calculation of stress as a function of strain and temperature requires, first, the determination of stress-strain curve points for a given temperature T or its parameters: Young modulus $E(T)$, strain hardening modulus, yield stress $\sigma_0(T)$ and tensile strength $ST(T)$ or ultimate tensile strength $UST(T)$. The searched curve can be determined based on the curves defined for the temperatures closest to the considered temperature, that is, the determination of parameters of stress-strain curve for temperature $T > T_1$ and $T < T_2$, where T_2 and T_1 denote temperatures for which the tensile curves are known (defined). In case of curve description by the points, the searched curve at the desired temperature T is calculated for individual points, using the proportionality principle, according to the relationship (Fig 3):

$$\sigma_i(T) = \sigma_i(T_1) + \frac{\sigma_i(T_2) - \sigma_i(T_1)}{T_2 - T_1} (T - T_1) \quad (8)$$

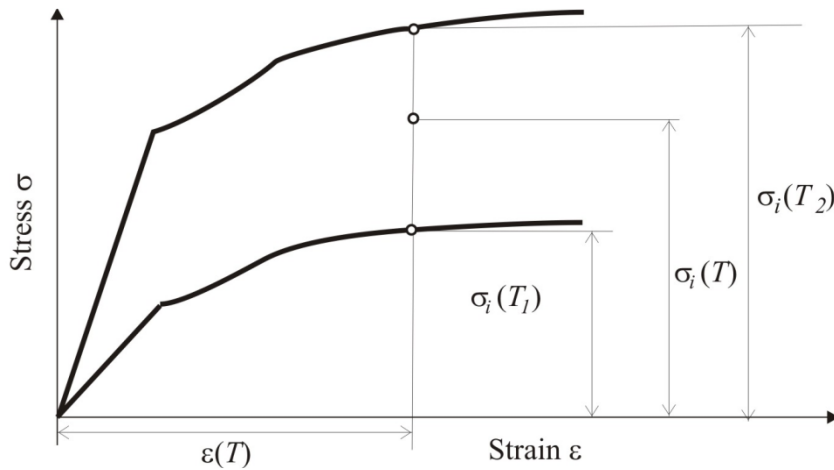

Fig. 3. Interpolation of stress-strain curve points.

Regardless of description method of the stress-strain curve, the stress values in the elastic range are determined analogously to the equation (1) according to Hooke's law:

$$\sigma(\varepsilon, T) = E(T)\varepsilon \quad (8)$$

In the elastic-plastic range, the stress value is determined depending on the description of the curve. In the case of the curve description by points, the calculation of strain values for strain ε we start from determining the points of the curve ε_i and ε_{i+1} (Fig. 4), between which there are strain value ε . The stress value is calculated from the dependence:

$$\sigma(\varepsilon, T) = \sigma_i(\varepsilon_i, T) + \frac{\sigma_{i+1}(\varepsilon_{i+1}, T) - \sigma_i(\varepsilon_i, T)}{\varepsilon_{i+1} - \varepsilon_i} (\varepsilon - \varepsilon_i) \quad (9)$$

In the case of describing the strain hardening curve with the function [x], the stress value is determined in accordance with the formula:

$$\sigma(\varepsilon, T) = \sigma_o(T) + \sigma_{sh}(\varepsilon - \varepsilon_o, T) \quad (10)$$

W metodach numerycznych, w których stosuje się najczęściej zależności $E = E(T)$, $\sigma_o = \sigma_o(T)$. Na rys. 4 and 5 przedstawiono wykresy tych zależności dla stali S235JR [10] and S355J2H [4].

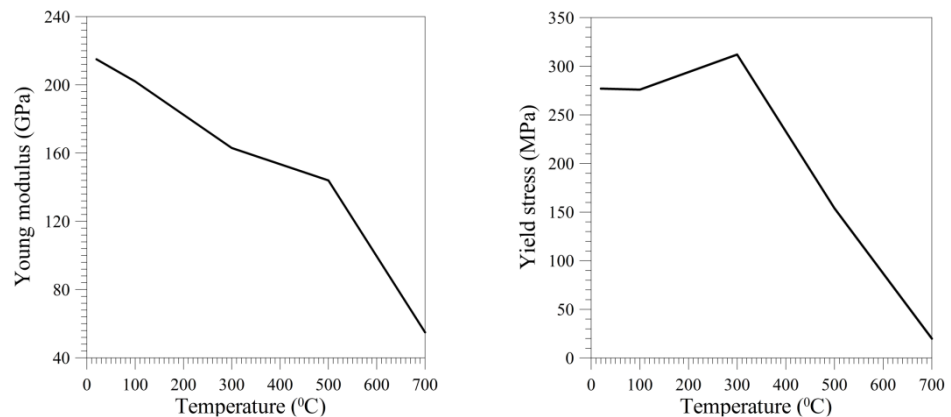

Fig. 4. Young's modulus and yield strength as a temperature function for S235JR steel.

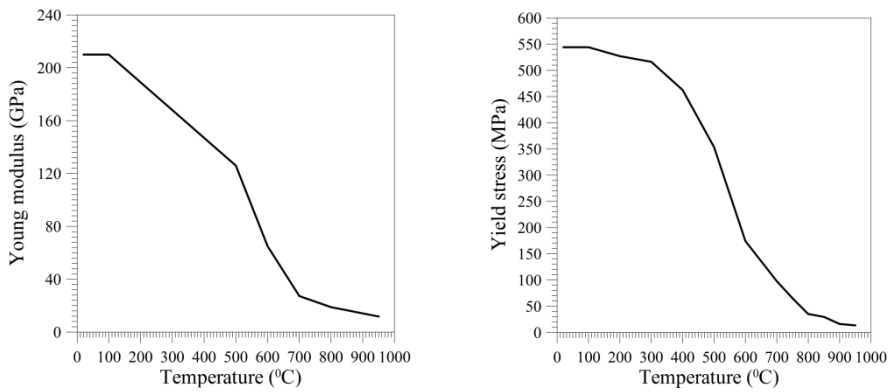

Fig. 5. Young's modulus and yield strength as a temperature function for S355J2H steel.

Example of computations.

In the example of computations, the models of tensile curves of S355J2H as a function of temperature based on the results of experimental studies contained in the research report Outinen et al. [1] is presented. The parameters of the Swift's and Hollomon's equations were determined in[11]. The comparison of the stress-strain curves described by Swift and Hollomon laws for the temperature 500 °C with the experimental results and the curves obtained by interpolation from 400 °C and 600 °C in Fig. 6 is presented.

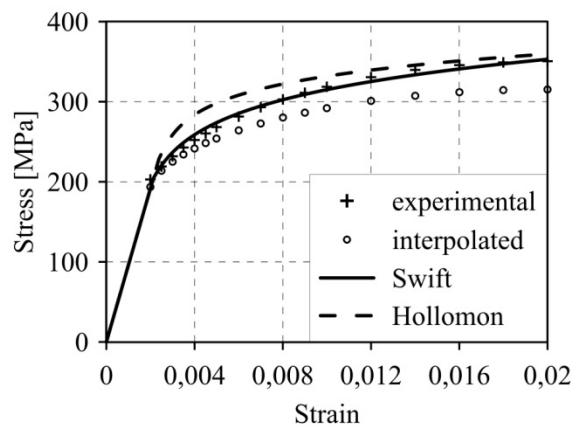

Fig. 6. The comparison of the stress-strain curves described by Swift and Hollomon laws for the temperature 500 °C with the experimental results and the curves obtained by interpolation.

References

- [1] Outinen J., Kaitila O., Mäkeläinen P. (2001) High-temperature testing of structural steel and modelling structure at fire temperatures. Research report. Helsinki University of Technology, Laboratory of Steel Structures, Publications 23, Espoo.
- [2] Chen J., Young B., Uy B., Behaviour of high strength structural steel at elevated temperatures, *J. Struct. Eng.* 2006, 1948 – 1954.
- [3] Gawad J., Szeliga D., Bator A., Pidvysockyy V., Pietrzyk M., 2004, Interpretation of the tensile test results interpretation based on two criterion optimization, In: Proc. 14. Conf. KomPlasTech, Informatics in Metal Technology, ed. M. Pietrzyk et al., Akapit, Cracow, 27-34.
- [4] Outinen J., Mäkeläinen P., Mechanical properties of structural steel at elevated temperatures and after cooling down, Second Workshop “Structures in Fire”, Christchurch, March 2012, 273 – 290.
- [5] Winczek J., A simplified method of predicting stresses in surfaced steel rods, *Journal of Materials Processing Technology*, 212 (2012) 1080 – 1088.
- [6] P. Ludwik, *Elemente der Technologischen mechanik*, Verlag von Julius Springer, Berlin 1909, p. 32. (<http://www.bookprep.com/read/mdp.39015002016650>)
- [7] Hollomon J. H., Tensile deformation, *Trans. Metall. Soc. AIME*, 1945, vol. 162, 268 – 290.
- [8] Hollomon J.H., Jaffe L.D., Time-temperature relations in tempering steel, *Trans. Metall. Soc. AIME*, 1945, No 1381, 1 – 26.
- [9] Swift H.W., Plastic instability under plane stress, *Journal of the Mechanics and Physics of Solids*, 1 (1952) 1 – 18.
- [10] Skorwoński W., Włóka A., Chmiel R., Modelling of strength properties of S235JR steel at increased temperature, *Structure and Environment*, 6 (2014) No 3, 32 – 37.
- [11] Winczek J., Ziobrowski P., On the strain-hardening parameters of S355J2H steel considering the influence of temperature, In: book of full texts of 20-th International Conference Engineering Mechanics 2014, May 12-15 Svratka, Czech Republik, 720 – 723.

COMPARISON OF THE ANALYTICAL AND NUMERICAL SOLUTIONS OF THE LAPLACE EQUATION

Ewa Węgrzyn-Skrzypczak¹, Tomasz Skrzypczak²

*¹Institute of Mathematics, Czestochowa University of Technology,
Czestochowa, Poland*

*²Institute of Mechanics and Machine Design Fundamentals, Czestochowa University of Technology,
Czestochowa, Poland*

¹ewa.skrzypczak@im.pcz.pl, ²t.skrzypczak@imipkm.pcz.pl

Keywords: Laplace equation, Fourier's method, Finite Element Method

Mathematical models of many physical phenomena (in fields such as electricity mechanics, magnetism, thermodynamics, etc.) are described using second order linear partial differential equations, which are called equations of mathematical physics. The task of determining functions that describe these equations leads to infinitely many solutions. For specific cases a special solutions that meet certain initial and boundary conditions are sought [1].

In order to solve equations of mathematical physics, the analytical or numerical methods are used. Analytical methods allow to obtain an exact solution of considered problem, but they can not be used in all cases. Numerical methods can be used in almost every case, but they give approximated results .

One of the most popular analytical method used to solve equations of mathematical physics is the Fourier method. It is based on finding a solution in the form of the product of functions where each of them is dependent only on one variable. The use of appropriate boundary conditions makes possible to determine the value of constants appearing in the solutions [2,3].

One of the numerical methods widely used in the solving of equations of mathematical physics is the Finite Element Method (FEM). In this method, the analyzed area is divided into sub-areas, called finite elements, in which approximation functions are determined. These functions are algebraic polynomials, which are determined on the base of the rules of approximation interpolation. The form of the approximation functions depends on the number and positions of the nodes located within the finite element. Unknown variables in the nodes, such as temperature values are determined with the use of known boundary conditions. Finally the discrete set of the nodal variables is calculated as the solution of the system of algebraic equations [4,5,6].

In order to verify the correctness of the results obtained with the use of numerical method, they are compared with the analytical solution of the considered problem. Obtaining good compliance of the compared analytical and numerical

solutions makes possible to confirm the correctness of the used numerical method [7].

In this paper the analytical and numerical solutions of the Laplace equation in two-dimensional region are presented. The analytical solution of the equation is obtained using the Fourier series. The numerical model is based on the Finite Element Method. The results obtained with the use of both methods are compared in order to verify the accuracy of numerical implementation.

References

- [1] Tichonow A. N., Samarski A.A., *Równania fizyki matematycznej*, PWN, Warszawa 1963.
- [2] Zaporozec G., *Metody rozwiązywania zadań z analizy matematycznej*, WNT, Warszawa, 1967.
- [3] Fichtenholz G. M., *Rachunek różniczkowy i całkowy*, PWN, Warszawa 1999.
- [4] Cichoń Cz., *Metody obliczeniowe. Wybrane zagadnienia*, Wydawnictwo Politechniki Świętokrzyskiej, Kielce, 2005.
- [5] Majchrzak E., Mochnacki B., *Metody numeryczne*, Wydawnictwo Politechniki Śląskiej, Gliwice 1998.
- [6] Zienkiewicz O.C., *Metoda elementów skończonych*, ARKADY, Warszawa 1972.
- [7] Węgrzyn-Skrzypczak E., Skrzypczak T.: Analytical and Numerical Solution of the Heat Conduction Problem in the Rod, *Journal of Applied Mathematics and Computational Mechanics*. nr 4(16), 2017, s.79-86.

INVERTIBLE POLYNOMIAL MAPPINGS WHICH HAVE ONE ZERO AT INFINITY

Magdalena Woźniakowska

*Katedra Metodyki Nauczania Matematyki, University of Lodz, Poland
magdalena_wozniakowska@wp.pl*

Keywords: **invertible polynomial mappings, one zero at infinity**

Poster contains theorems describing invertible polynomial mappings

$$(f, h): C^2 \rightarrow C^2$$

which have constant jacobian, don't equal zero and one zero at infinity. There are given formulas on inverse for some cases.

First case are polynomials having form:

$$\begin{aligned} f &= X^{2n+1} + f_{2n} + \dots + f_1 \\ h &= X^2 + h_1 \end{aligned}$$

These mappings are not invertible.

Next case are polynomials

$$\begin{aligned} f &= X^{2n} + f_{2n-1} + \dots + f_1 \\ h &= X^2 + h_1 \end{aligned}$$

which have constant jacobian. Then f will have form

$$\begin{aligned} f &= h^n + A_1 h^{n-1} + \dots + A_{n-1} h + a_1 X \\ h &= X^2 + h_1 \end{aligned}$$

and for some conditions f and h are invertible.

Thus poster presents theorems for few examples of polynomial mappings, which are invertible and don't invertible.

References

- [1] Lara-Dziembek S., Pawlak E., Biernat G., Woźniakowska M., A second example of non-Keller mapping, *Journal of Applied Mathematics and Computational Mechanics*, Vol. 15, issue 2, 2016
- [2] Lara-Dziembek S., Pawlak E., Biernat G., Woźniakowska M., An example of non-Keller mapping, *Journal of Applied Mathematics and Computational Mechanics*, Vol. 15, issue 1, 2016
- [3] Biernat G., Ciekot A., The non-Keller mapping with one zero at infinity, *Journal of Applied Mathematics and Computational Mechanics*, Vol. 15, issue 4, 2016

DIFFERENTIAL TRANSFORMATION METHOD FOR A CANTILEVER BEAM WITH DAMAGE

Izabela Zamorska

*Institute of Mathematics, Czestochowa University of Technology,
Czestochowa, Poland
izabela.zamorska@im.pcz.pl*

Keywords: **differential transformation method, Euler-Bernoulli beam, damage, free vibration**

The Differential Transformation Method (DTM) is an updated version of the Taylor series problem. Even though the method has some drawbacks (e.g. small convergence region) is very useful to obtain solutions of many engineering problems which are described by the ordinary or partial differential equations.

In this work differential transformation method is proposed as a method of analytical solving of vibration problem of a cantilever beam. There was assumed various parameters describing geometrical and physical properties of the beam and damage occur at one point of the system. Results of the application of the DTM is reducing the problem of vibrations into solving the system of algebraic linear equations supplemented with boundary conditions for the clamped-free beam and conditions (continuity) associated with the occurrence of damage.

References

- [1] Liu Z., Yin Y., Wang F., Zhao Y., Cai L., Study on modified differential transform method for free vibration analysis of uniform Euler-Bernoulli beam, *Structural Engineering and Mechanics* 2013, 48(5), 697-709.
- [2] Zamorska I., Solution of differential equation for the Euler-Bernoulli beam, *Journal of Applied Mathematics and Computational Mechanics* 2014, 13(4), 157-162.
- [3] Zamorska I., Cekus D., Miara M., Application of the vibration method for damage identification of a beam with a variable cross-sectional area, *MATEC Web of Conferences* 2018, 157, 08012 (MMS 2017)
- [4] Zhou J.K., *Differential transformation and its Application for Electrical Circuits*, Huazhong University Press, Wuhan, 1986 (in Chinese).
- [5] Zozulya V.V., Green's matrices for the BVP for the system of ODE of the first order: applications to the beam theories, *Arch Appl. Mech.* 2017, 87, 1605-1627.

DIDACTIC PANEL

In this year the Didactic Panel in Polish is organized. This part of the conference proceedings concerns the new Law on Higher Education (act 2.0) which will apply from October 2018. On the next pages some abstracts about this subject are presented.

**PROFESSIONAL PRACTICES IN THE STUDY PROGRAM
ACCORDING TO LAW 2.0. REGIONAL POSSIBILITIES OF
PROFESSIONAL PRACTICES**

Jolanta Borowska

*Institute of Mathematics, Czestochowa University of Technology,
Czestochowa, Poland
jolanta.borowska@im.pcz.pl*

Słowa kluczowe: **Ustawa 2.0, praktyki zawodowe**

Ustawa 2.0 - Prawo o szkolnictwie wyższym i nauce, dotycząca zmian w szkolnictwie wyższym, opracowywana jest przez Ministerstwo Nauki i Szkolnictwa Wyższego, [1].

Zgodnie z projektem Ustawy 2.0 studia będą prowadzone na poziomie: studiów pierwszego stopnia, studiów drugiego stopnia oraz jednolitych studiów magisterskich. Przy czym będą funkcjonowały dwa profile studiów:

- praktyczny, na którym ponad połowa punktów ECTS jest przypisana zajęciom kształującym umiejętności praktyczne,
- ogólnoakademicki, na którym ponad połowa punktów ECTS jest przypisana zajęciom związanym z prowadzoną w uczelni działalnością naukową.

Program studiów o profilu praktycznym przewiduje praktyki zawodowe w wymiarze co najmniej:

- 6 miesięcy – w przypadku studiów pierwszego stopnia i jednolitych studiów magisterskich,
- 3 miesięcy – w przypadku studiów drugiego stopnia.

Powyższe zasady związane z praktykami zawodowymi nie dotyczą studiów przygotowujących do wykonywania następujących zawodów: lekarza, lekarza dentystry, farmaceuty, pielęgniarki, położnej, diagnosty laboratoryjnego, fizjoterapeuty, ratownika medycznego, lekarza weterynarii, architekta oraz nauczyciela. W przypadku praktyk dla wyżej wymienionych zawodów uwzględnia się standardy kształcenia, [2].

Wykaz źródeł

- [1] <http://naukawpolsce.pap.pl/aktualnosci/news%2C459723%2Cjaroslaw-gowin-przedstawil-zalozenia-nowej-ustawy-o-szkolnictwie-wyzszym.html>
- [2] <http://konstytucjadlanauki.gov.pl/content/uploads/2018/03/projekt-ustawy-prawo-o-szkolnictwie-wyzszym-i-nauce-26032018.pdf>

**INTERDISCIPLINARY STUDIES
ACCORDING TO LAW 2.0**

Joanna Klekot

*Institute of Mathematics, Częstochowa University of Technology,
Częstochowa, Poland
joanna.klekot@im.pcz.pl*

W projekcie nowej ustawy o szkolnictwie wyższym i nauce nie występuje pojęcie studiów interdyscyplinarnych. Nie oznacza to jednak, że Ustawa 2.0 uniemożliwia prowadzenie takich kierunków.

Zgodnie z projektem uczelnia przyporządkowuje kierunek studiów do co najmniej jednej dyscypliny. W przypadku przyporządkowania kierunku studiów do więcej niż jednej dyscypliny, wskazuje dyscyplinę wiodącą i w jej ramach ma być uzyskiwana ponad połowa efektów uczenia się.

Utworzenie studiów na określonym kierunku, poziomie i profilu wymaga pozwolenia ministra. Pozwolenia nie wymaga utworzenie studiów na kierunku przyporządkowanym do dyscypliny (wiodącej), w której uczelnia posiada kategorię naukową A+ albo A.

**THE REQUIREMENTS FOR GRANTING THE RIGHT TO
CONDUCT STUDIES WITH A PRACTICAL PROFILE
IN THE CONTEXT OF THE HIGHER EDUCATION AND SCIENCE
LAW (ACT 2.0)**

Sylvia Lara-Dziembek

*Institute of Mathematics, Czestochowa University of Technology,
Czestochowa, Poland
sylvia.lara@im.pcz.pl*

Słowa kluczowe: szkolnictwo wyższe, reforma szkolnictwa wyższego w Polsce, Ustawa Prawo o Szkolnictwie Wyższym i Nauce (Ustawa 2.0), kształcenie akademickie, profil kształcenia

Zróżnicowanie oferty dydaktycznej poprzez wprowadzenie dwóch profili kształcenia: praktycznego i ogólnoakademickiego zostało po raz pierwszy uwzględnione w nowelizacji ustawy Prawo o Szkolnictwie Wyższym z dnia 11.07.2014 r. Obecna ustawa Prawo o Szkolnictwie Wyższym i Nauce (Ustawa 2.0) również obejmuje te dwa profile kształcenia, przy czym przewiduje wzmocnienie ich odrębności. W przypadku profilu praktycznego wprowadza mechanizmy motywujące do prowadzenia studiów odpowiadających wyzwaniom gospodarki i przygotowujących absolwentów do potrzeb rynku pracy. W świetle ustawy profil praktyczny obejmuje moduły zajęć służące zdobywaniu przez studenta umiejętności praktycznych i kompetencji społecznych, przy założeniu, że ponad połowa programu studiów określonego w punktach ECTS to zajęcia praktyczne kształtujące te umiejętności i kompetencje, w tym umiejętności uzyskiwane na zajęciach warsztatowych, które są prowadzone przez osoby posiadające doświadczenie zawodowe zdobyte poza Uczelnią. Prezentacja przedstawia uwzględnione w Ustawie 2.0 regulacje prawne oraz wymogi uruchamiania kierunków studiów o profilu praktycznym.

References

- [1] <https://www.nauka.gov.pl/> (z dnia 16.05.2018)
- [2] http://www.bip.nauka.gov.pl/g2/oryginal/2014_11/7afac344684783d80578b24c044abc81.pdf (z dnia 16.05.2018)

**THE REQUIREMENTS FOR GRANTING THE RIGHT TO
CONDUCT STUDIES WITH A GENERAL ACADEMIC PROFILE
IN THE CONTEXT OF THE HIGHER EDUCATION AND SCIENCE
LAW (ACT 2.0)**

Edyta Pawlak

*Institute of Mathematics, Czestochowa University of Technology,
Czestochowa, Poland
edyta.pawlak@im.pcz.pl*

Słowa kluczowe: szkolnictwo wyższe, reforma szkolnictwa wyższego w Polsce, Ustawa Prawo o Szkolnictwie Wyższym i Nauce (Ustawa 2.0), kształcenie akademickie, profil kształcenia

Profilowanie studiów wyższych wprowadziła nowelizacja ustawy Prawo o Szkolnictwie Wyższym z dnia 11.07.2014 r., wówczas to nastąpiło rozróżnienie profili kształcenia na profil ogólnoakademicki i profil praktyczny. Zgodnie z założeniami ustawy profil ogólnoakademicki to profil programu kształcenia obejmujący moduły zajęć powiązane z prowadzonymi w Uczelni badaniami naukowymi, realizowany przy założeniu, że ponad połowa programu studiów (mierzona punktami ECTS) obejmuje zajęcia służące zdobywaniu przez studenta pogłębionej wiedzy. Ustawa Prawo o Szkolnictwie Wyższym i Nauce (Ustawa 2.0) wprowadza jeszcze bardziej wyraźny podział na profile kształcenia, a w przypadku profilu ogólnoakademickiego kładzie nacisk na zwiększenie roli i wykorzystania wyników badań naukowych prowadzonych w jednostce w procesie kształcenia. W prezentacji przedstawione zostaną podstawowe kwestie organizacyjne i prawne związane z prowadzeniem studiów o profilu ogólnoakademickim w świetle Ustawy 2.0, z uwzględnieniem możliwości uruchomienia studiów o takim profilu na kierunku Matematyka na Wydziale Inżynierii Mechanicznej i Informatyki Politechniki Częstochowskiej.

References

- [1] <https://www.nauka.gov.pl/> (z dnia 16.05.2018)
- [2] http://www.bip.nauka.gov.pl/g2/oryginal/2014_11/7afac344684783d80578b24c044abc81.pdf (z dnia 16.05.2018)
- [3] <https://nkn.gov.pl/ustawa-2-0/> (z dnia 16.05.2018)
- [4] <http://konstytucjadlanauki.gov.pl/> (z dnia 16.05.2018)
- [5] <http://konstytucjadlanauki.gov.pl/content/uploads/2018/03/projekt-ustawy-prawo-o-szkolnictwie-wyszym-i-nauce-26032018.pdf> (z dnia 16.05.2018)

**PRINCIPLES OF CLASSIFICATION OF SCIENTIFIC
DISCIPLINES ACCORDING TO LAW 2.0 (LAW ON HIGHER
EDUCATION AND SCIENCE), STATE ON JUNE 2018**

Jowita Rychlewska

*Institute of Mathematics, Czestochowa University of Technology,
Czestochowa, Poland
jowita.rychlewska@im.pcz.pl*

Słowa kluczowe: **Ustawa 2.0, dyscypliny naukowe, ewaluacja**

Nowa ustawa o szkolnictwie wyższym, zwana Konstytucją dla Nauki (Ustawa 2.0), opracowywana jest od ponad dwóch lat. Projekt znolizowanej ustawy został przedstawiony 22 stycznia 2018 roku przez Ministra Nauki i Szkolnictwa Wyższego Jarosława Gowina. Jedną z kluczowych zmian dotyczy nowego podziału dyscyplin naukowych. W chwili obecnej w Polsce mamy 8 obszarów wiedzy, 22 dziedziny nauki i sztuki oraz 102 dyscypliny naukowe. Według Ministerstwa Nauki i Szkolnictwa Wyższego „problemem jest rozdrobniona klasyfikacja obszarów wiedzy, dziedzin i dyscyplin, która jest powiązana z uprawnieniami do prowadzenia studiów wyższych i studiów doktoranckich oraz do nadawania stopni w nauce i sztuce, jest źródłem poważnych problemów w prowadzeniu interdyscyplinarnych badań naukowych. Nie służy też właściwej prezentacji Polski w światowym obiegu nauki”, [1]. Z tego względu została zaproponowana nowa klasyfikacja dziedzin i dyscyplin nauki, oparta na klasyfikacji OECD (Organizacja Współpracy Zagranicznej i Rozwoju). Według klasyfikacji OECD wyróżnia się 6 dziedzin nauki (nauki przyrodnicze, nauki inżynieryjne i techniczne, nauki medyczne i nauki o zdrowiu, nauki rolnicze, nauki społeczne, nauki humanistyczne) i 41 dyscyplin. Matematyka znajduje się w grupie nauk przyrodniczych. Oczywiście, dopóki nie powstanie ostateczna wersja nowej listy nie można być pewnym przeniesienia klasyfikacji OECD wprost, niemniej jednak można przypuszczać, że jej zasadniczy trzon nie zostanie naruszony.

Jedną z najważniejszych konsekwencji wprowadzenia nowego zestawienia dyscyplin naukowych jest przedstawiony w projekcie Ustawy 2.0 nowy sposób prowadzenia ewaluacji jakości działalności naukowej. Ewaluacji będą poddawane poszczególne dyscypliny nauki prowadzone na uczelni, a nie jak do tej pory jednostki organizacyjne uczelni. Według projektu ustawy, jak wyjaśniał minister Gowin, „to uczelniom, a nie ich jednostkom organizacyjnym, będą przypisane uprawnienia do prowadzenia studiów i nadawania stopni naukowych. To uczelnie, a nie wydziały, będą przedmiotem ewaluacji w przekroju poszczególnych dyscyplin”, [2]. W wyniku ewaluacji uczelnia może uzyskać jedną z pięciu kategorii: A+, A, B+, B, C. Przynależność do jednej z tych kategorii determinuje możliwość nadawania stopni naukowych i tworzenia nowych kierunków

References

- [1] https://www.nauka.gov.pl/g2/oryginal/2017_10/4950c67f83e039c347667e77bcbdcfef.pdf
- [2] <http://naukawpolsce.pap.pl/aktualnosci/news%2C459723%2Cjaroslaw-gowin-przedstawil-zalozenia-nowej-ustawy-o-szkolnictwie-wyzszym.html>